

CROWN Boiler Co.

D E S I G N E D T O L E A D

BWF Series

Gas-Fired Fan Assisted Hot Water Boilers

INSTALLATION INSTRUCTIONS

These instructions must be affixed on or adjacent to the boiler



Models:

- BWF061
- BWF095
- BWF128
- BWF162
- BWF195
- BWF229

WARNING: Improper installation, adjustment, alteration, service or maintenance can cause property damage, injury, or loss of life. For assistance or additional information, consult a qualified installer, service agency or the gas supplier. This boiler requires a special venting system. Read these instructions carefully before installing.

CROWN Boiler Co

Manufacturer of Hydronic Heating Products

P.O. Box 14818 3633 I. Street

Philadelphia, PA 19134

Tel: (215) 535-8900 • Fax: (215) 535-9736 • www.crownboiler.com

Table of Contents

I	Product Description.....	2
II	Specifications.....	2
III	Before Installing.....	3
IV	Locating the Boiler.....	3
V	Air for Combustion and Ventilation.....	5
VI	Venting.....	9
	Horizontal Vent System Design.....	9
	Vertical Vent System Design.....	14
	Vent System Assembly.....	18
VII	Gas Piping.....	25
VIII	System Piping.....	26
IX	Wiring.....	31
X	Start-up and Checkout.....	36
XI	Service and Maintenance.....	40
XII	Troubleshooting Charts.....	43
XIII	Parts.....	47

I Product Description

The BWF series boiler is a cast iron gas fired boiler designed for use in forced hot water heating systems. The BWF is intended for installations where a usable chimney is not available. The BWF is normally vented using an approved vertical or horizontal AL29-4C stainless steel venting system, which is not included with the boiler. If a suitable chimney is available, the BWF series can be vented into it using an optional BWF Category I Vent Kit available from Crown. The BWF requires an adequate source of clean combustion air in the boiler room.

The BWF boiler is not designed for use in gravity or "open" heating systems. Where an adequate source of clean indoor combustion air cannot be guaranteed, use a direct vent boiler such as the Crown CSC series.

II Specifications

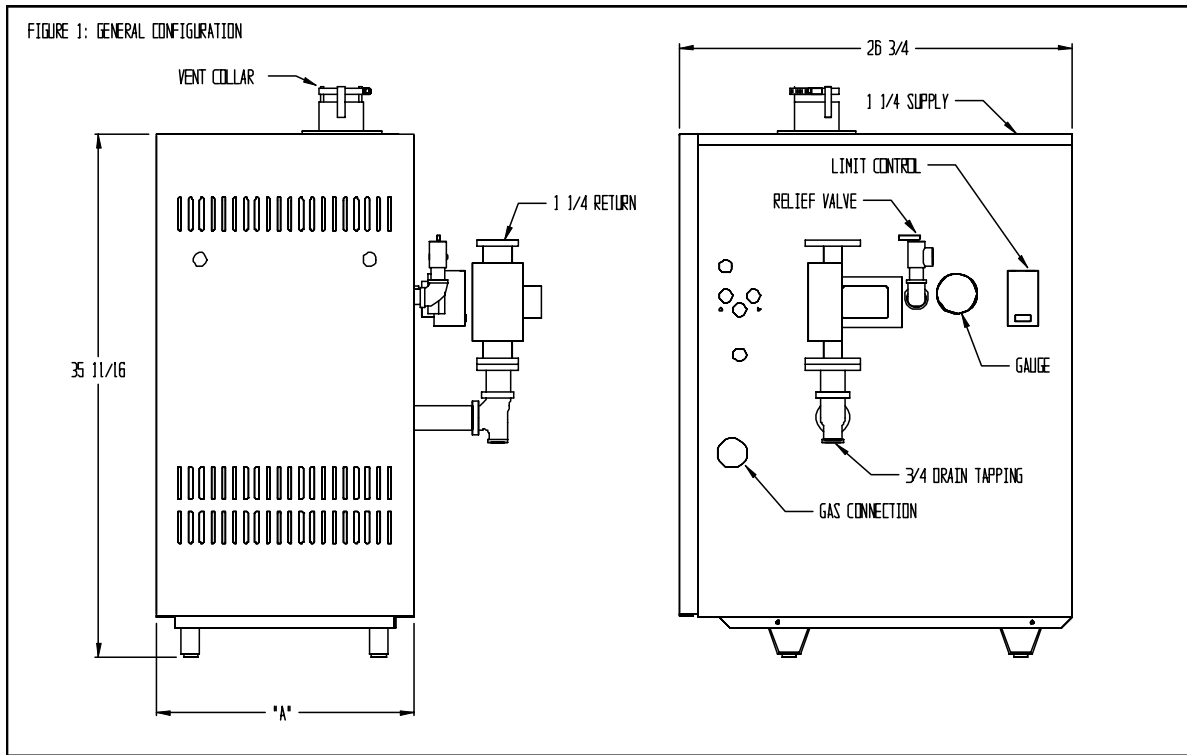

TABLE 1: SPECIFICATIONS

MODEL*	NO. SECTIONS	INPUT (BTU/hr)	D.O.E. HEATING CAPY. (BTU/hr)	IBR NET RATING (BTU/hr)	AFUE (%)	FIG. 1 DIMENSION "A" (IN.)	VENT DIA. (IN.)	WATER CONTENT (GAL.)
BWF061EN	3	61,000	51,000	44,000	83.3	14 1/4	3	3.2
BWF095EN	4	95,000	78,000	68,000	83.1	17 1/2	3	4.0
BWF128EN	5	128,000	106,000	92,000	82.8	20 3/4	3	4.7
BWF162EN	6	162,000	134,000	117,000	82.5	24	3	5.5
BWF195EN	7	195,000	161,000	140,000	82.3	27 1/4	4	6.3
BWF229EN	8	229,000	189,000	164,000	82.0	30 1/2	4	7.0

* MODELS SHOWN ARE FOR NATURAL GAS. REPLACE "N" WITH "L" SUFFIX FOR PROPANE MODEL NUMBER (e.g. BWF061EL). PERFORMANCE RATINGS ARE THE SAME FOR BOTH FUELS

III Before Installing

- 1) Safe, reliable operation of this boiler depends upon installation by a professional heating contractor in strict accordance with this manual and the authority having jurisdiction.
 - In the absence of an authority having jurisdiction, installation must be in accordance with this manual and the *National Fuel Gas Code*, ANSI Z223.1
 - In Canada, installation must be in accordance with CSA B149 (*Installation Code for Gas Burning Appliances and Equipment*).
 - Where required by the authority having jurisdiction, this installation must conform to the *Standard for Controls and Safety Devices for Automatically Fired Boilers* (ANSI/ASME CSD-1)
- 2) Read Section VI to verify that the boiler can be vented in accordance with these instructions.
- 3) Make sure that the boiler is correctly sized:
 - For heating systems employing convection radiation (baseboard or radiators) use an industry accepted sizing method such as the *I=B=R Heat Loss Calculation Guide* (Pub. #H21 or #H22) published by the Hydronics Institute in Berkeley Heights, NJ.
 - For new radiant heating systems refer to the radiant tubing manufacturer's boiler sizing guidelines.
 - For systems including a Crown Mega-Stor indirect water heater, size the boiler to have either the DOE Heating Capacity required for the Mega-Stor or the net rating required for the heating system, whichever results in the larger boiler.
 - For systems that incorporate other indirect water heaters, refer to the indirect water heater manufacturer's instructions for boiler output requirements.
- 4) Make sure that the boiler received is configured for the correct gas (natural or LP).
- 5) For installations at altitudes above 2000ft, special orifice and pressure switches may be required. Make sure that the boiler is configured for use at the correct altitude.

IV Locating the Boiler

- 1) Clearances:
 - Observe the minimum clearances shown below. These clearances apply to all combustible construction, as well as non-combustible walls and doors. Also see Figure 2.
 - Front – 6”
 - Left Side – 1”
 - Right Side – 4”
 - Rear – 1”
 - Top – 36”
 - Vent Pipe – 5”
 - A 24” service clearance from the jacket is recommended on the left, right, and front of the boiler. These clearances may be reduced to those shown in Figure 2, however servicing the boiler will become increasingly difficult as these service clearances are reduced.
 - If the right side 24” service clearance is reduced, adequate clearance must be maintained to easily read both the gauge and the limit control. Alternatively, access to the gauge and limit may be provided using a door.
- 2) The boiler must be installed on a hard level surface. This surface may be combustible.

FIGURE 2: MINIMUM CLEARANCES FROM BOILER TO ALL TYPES OF COMBUSTIBLE CONSTRUCTION AND NON-COMBUSTIBLE WALLS, DOORS, AND CEILINGS

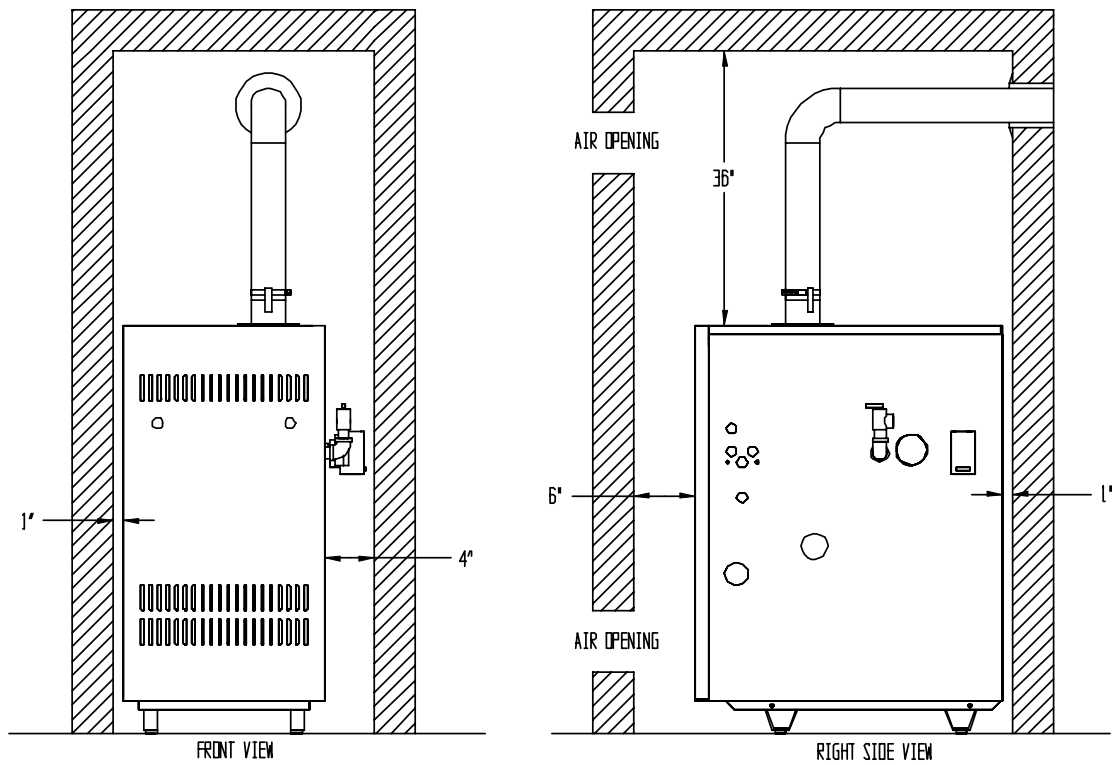

- 3) Do not install this boiler in an area where large amounts of airborne dust will be present, such as a workshop. Do not install in a location where sources of hydrocarbons will be stored or used. Some common sources of hydrocarbons include bleaches, fabric softeners, paints, cleaners, refrigerants, and cat boxes. Traces of these chemicals can be drawn into the boiler, causing severe corrosion damage to the boiler and/or objectionable odors.
- 4) The boiler should be located so as to minimize the length of the vent system while still meeting the requirements in Section VI.
- 5) Do not install this boiler over carpeting.
- 6) Do not install this boiler directly on a surface that may get wet. Raise the boiler on a pad.

V Air for Combustion and Ventilation

Sufficient fresh air must be supplied for both combustion and ventilation. Provisions for combustion, ventilation, and dilution air for gas utilization equipment must be made in accordance with local building codes, or in the absence of such codes, in accordance with Sections 5.3.3 and 5.3.4 (“Air for Combustion and Ventilation”) of the National Fuel Gas Code, NFPA 54/ANSI Z223.1.

To ensure an adequate combustion and ventilation air supply, start by determining whether the boiler is to be installed in a building of unusually tight construction. A building of unusually tight construction is defined by the *National Fuel Gas Code* as having all of the following features:

- Walls and ceilings exposed to outside atmosphere have a continuous water vapor retarder with a rating of 1 perm or less with openings gasketed and sealed.
- Weather stripping has been added on openable windows and doors.
- Caulking and sealants are applied to areas such as joints around window and door frames, between sole plates and floors, between wall-ceiling joints, between wall panels, at penetrations for plumbing, electrical, and gas lines, and at other openings.

If the building is of unusually tight construction, see the instructions on page 6. Otherwise, follow the instructions below.

For Buildings of Other than Unusually Tight Construction

1) Determine whether the boiler is to be installed in a confined space - A confined space is defined by the *National Fuel Gas Code* as having a volume less than 50 cubic feet per 1000 BTU/hr input of all appliances installed in that space. To determine whether the boiler room is a confined space:

- a. Total the input of all appliances in the boiler room in thousands of BTU/hr. Round the result to the next highest 1000 BTU/hr.
- b. Find the volume of the room in cubic feet. The volume of the room in cubic feet is:

Length (ft) x width (ft) x ceiling height (ft)

In calculating the volume of the boiler room, consider the volume of adjoining spaces only if no doors are installed between them. If doors are installed between the boiler room and an adjoining space, do not consider the volume of the adjoining space, even if the door is normally left open.

- c. Divide the volume of the boiler room by the input in thousands of BTU/hr. If the result is less than 50, the boiler room is a confined space.

Example:

A BWF229 and a water heater are to be installed in a room measuring 6ft – 3 in x 7ft with an 8 ft ceiling. The water heater has an input of 30000 BTU/hr:

Total input in thousands of BTU/hr = (229000 BTU/hr + 30000 BTU/hr) / 1000 = 259

Volume of room = 6.25 ft x 7 ft x 8 ft = 350 ft³

350/259 = 1.35 Since 1.35 is less than 50, the boiler room is a confined space.

If the boiler is in an unconfined space– Natural infiltration into the boiler room will normally provide adequate air for combustion and ventilation without additional louvers or openings into boiler room.

If the boiler is in a confined space – Provide two openings into the boiler room, one near the floor and one near the ceiling. The top edge of the upper opening must be within 12” of the ceiling and the bottom edge of the lower opening must be within 12” of the floor (Fig 3).

- Each opening must have a free area of 1 square inch per 1000 BTU/hr input of all gas burning appliances in the boiler room. The minimum opening dimension is 3 inches. Minimum opening free area is 100 square inches per opening.
- If the total volume of both the boiler room and the room to which the openings connect is less than 50 cubic feet per 1000 BTU/hr of total appliance input, install a pair of identical openings into a third room. Connect additional rooms with openings until the total volume of all rooms is at least 50 cubic feet per 1000 BTU/hr of input.
- The “free area” of an opening takes into account the blocking effect of mesh, grills, and louvers. Where screens are used, they must be no finer than 1/4” (4 x 4) mesh.
- If providing openings into adjacent rooms is undesirable, combustion and ventilation air can be brought to the boiler room from outdoors. See the instructions under “For Buildings of Unusually Tight Construction”

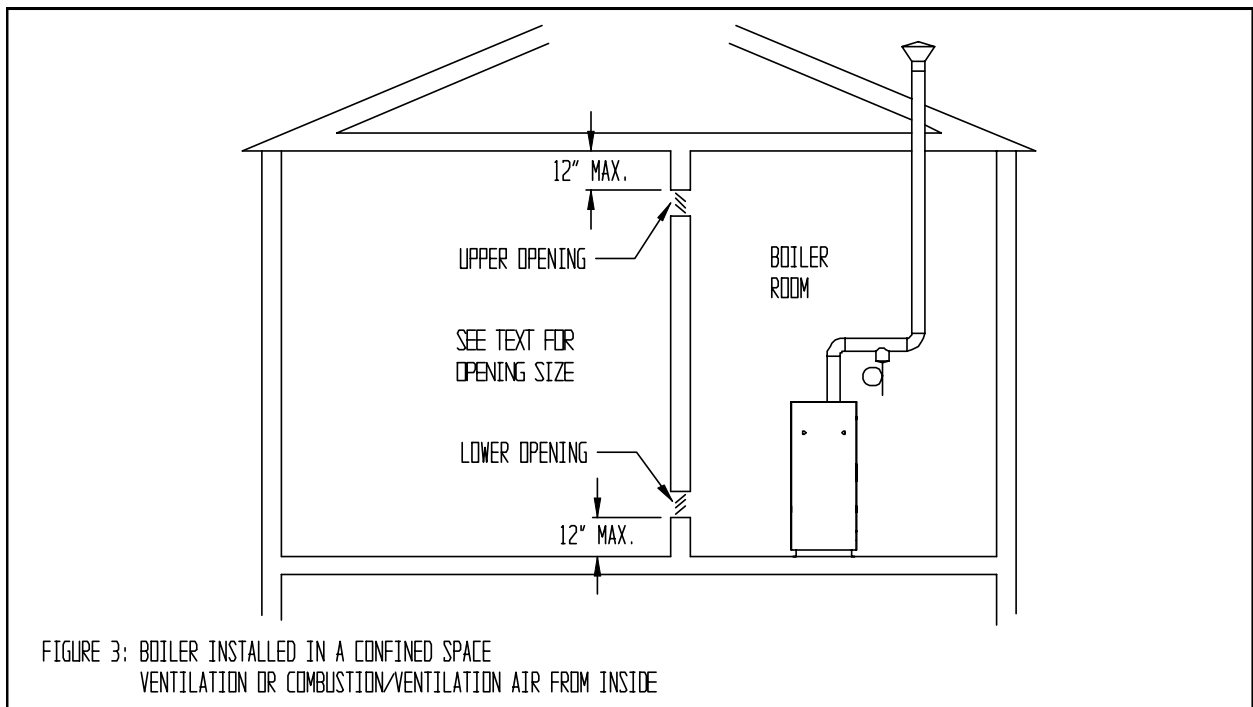

For Buildings of Unusually Tight Construction

- a) Openings must be installed between the boiler room and the outdoors or a ventilated space, such as an attic or crawl space, which communicates directly with the outdoors.
- b) Two openings are required. The top edge of the upper opening must be within 12 inches of the ceiling. The bottom edge of the lower opening must be within 12 inches of the floor.
- c) Size openings and ducts as follows:
 - Vertical ducts or openings directly outdoors (Fig 4, Fig 5, Fig 6) – Each opening must have a free cross sectional area of 1 square inch per 4000 BTU/hr of the total input of all gas-fired appliances in the boiler room. Minimum opening size is 3 inches. Ducts must have the same cross sectional area as the openings to which they connect.
 - Openings to outdoors via horizontal ducts (Fig 7) - Each opening must have a free cross sectional area of 1 square inch per 2000 BTU/hr of the total input of all gas-fired appliances in the boiler room. Minimum opening size is 3 inches. Ducts must have the same cross sectional area as the openings to which they connect.
 - The “free area” of an opening takes into account the blocking effect of mesh, grills, and louvers. Where screens are used, they must be no finer than 1/4” (4 x 4) mesh.

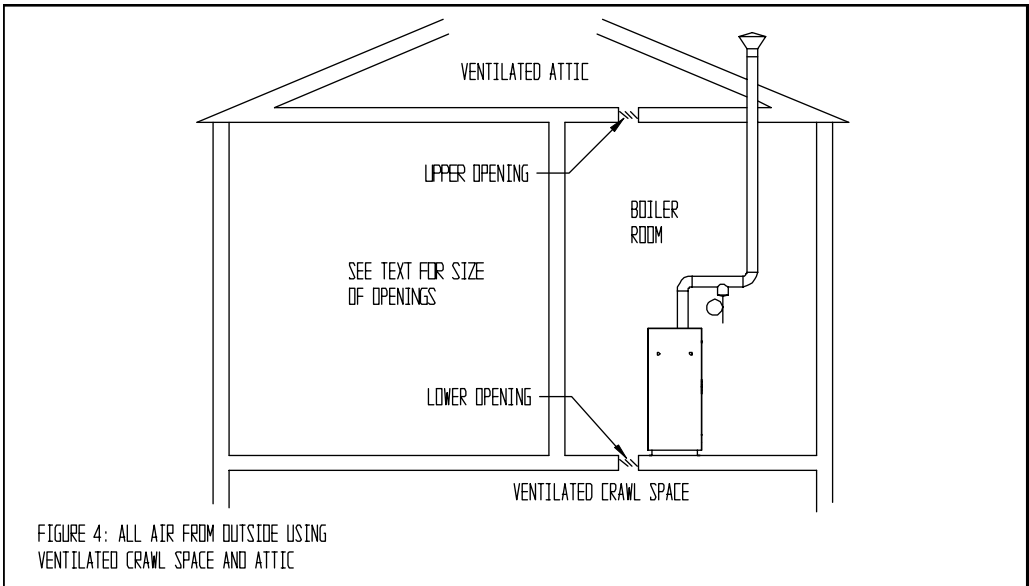

FIGURE 4: ALL AIR FROM OUTSIDE USING VENTILATED CRAWL SPACE AND ATTIC

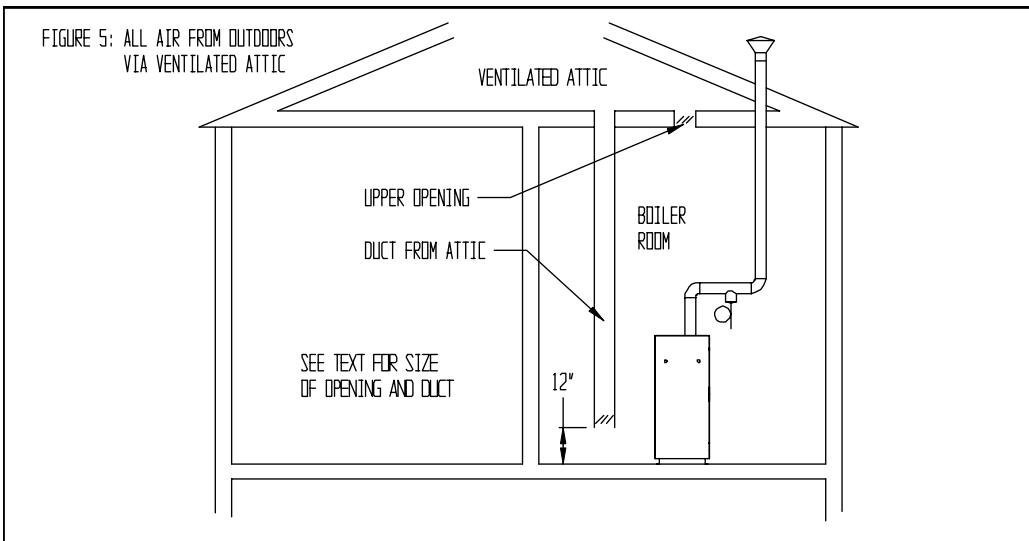

FIGURE 5: ALL AIR FROM OUTDOORS VIA VENTILATED ATTIC

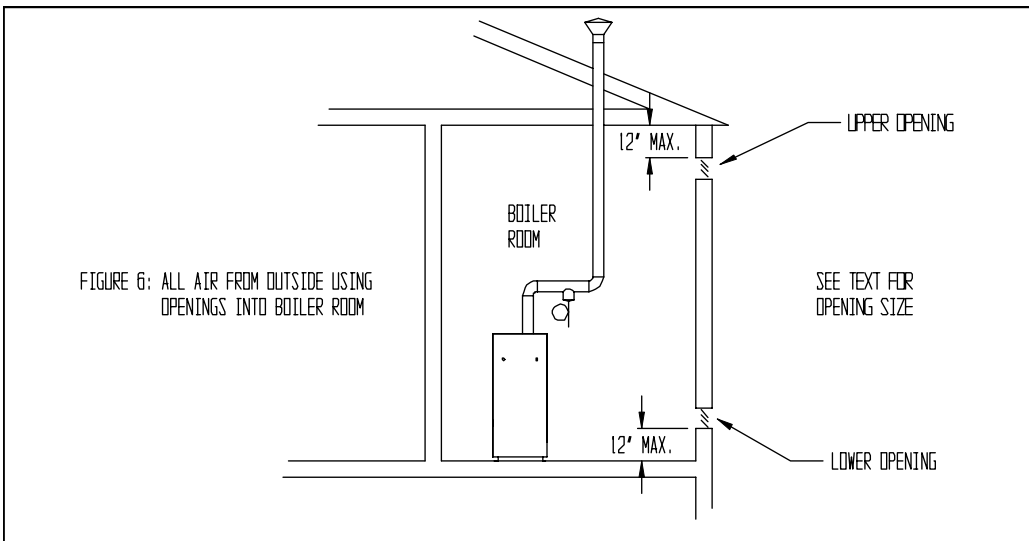
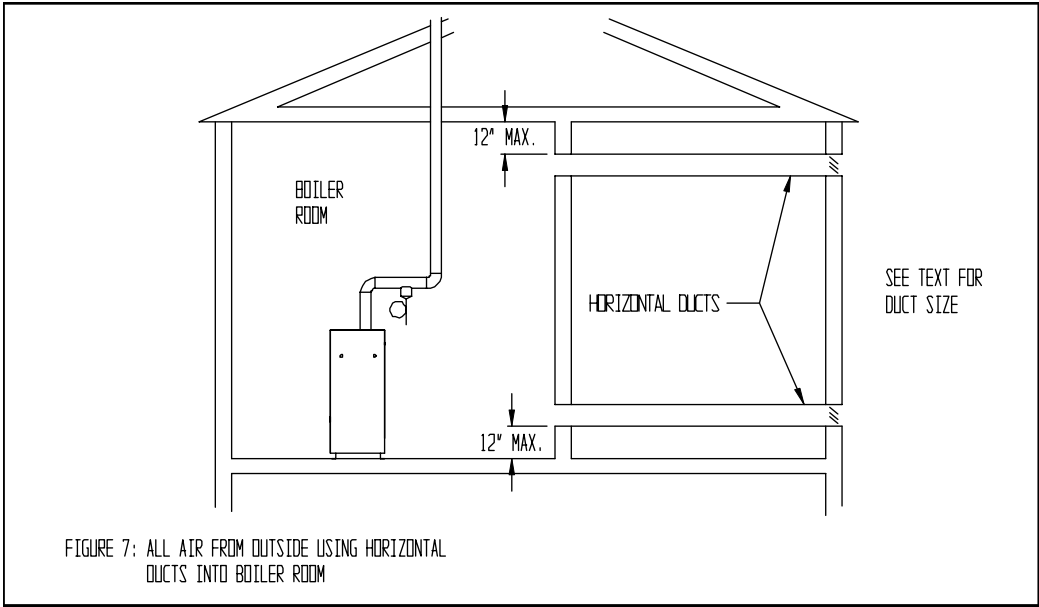

FIGURE 6: ALL AIR FROM OUTSIDE USING OPENINGS INTO BOILER ROOM

SEE TEXT FOR OPENING SIZE



VI Venting

There are three basic ways to vent the BWF boiler:

- Horizontal (“side wall”) venting using an approved AL29-4C stainless steel vent system.
- Vertical venting using an approved AL29-4C stainless steel vent system.
- Chimney venting using a masonry or “B” vent chimney and a special Category I Vent Kit available from Crown.

WARNING
 DO NOT ATTEMPT TO VENT A BWF SERIES BOILER INTO A MASONRY OR “B” VENT CHIMNEY WITHOUT THE CROWN CATEGORY I VENT KIT SHOWN IN TABLE III

Table 3 summarizes these three venting options. One of the columns in Table 3 must describe the planned vent system exactly.

TABLE 3: SUMMARY OF VENTING OPTIONS

CLASSIFICATION USED IN THIS MANUAL	HORIZONTAL DIRECT EXHAUST	VERTICAL DIRECT EXHAUST	CHIMNEY VENT
NATL. FUEL GAS CODE CLASSIFICATION	CATEGORY III	CATEGORY III	CATEGORY I
STRUCTURE PENETRATION	WALL	ROOF	ROOF
MAXIMUM LENGTH: BWF061 - BWF162 BWF195,BWF229 (using 4" Pipe) BWF195,BWF229 (using 3" Pipe)	45 FT + 1 EL 45 FT + 1 EL 30 FT + 1 EL	39.5 FT + 2 ELS 37 FT + 2 ELS 24.5 FT + 2 ELS	SIZE PER NATIONAL FUEL GAS CODE VENTING TABLES FOR FAN ASSISTED APPLIANCE
MINIMUM LENGTH: BWF061 - BWF162 BWF195,BWF229	2 FT + 1 EL 2 FT + 1 EL	6 FT + 2 ELS 6 FT + 2 ELS	
NOMINAL DIA.: BWF061 - BWF162 BWF195,BWF229	3" 3" or 4"	3" 3" or 4"	
MATERIAL	AL29-4C(*)	AL29-4C(*)	"B" VENT OR LINED MASONRY CHIMNEY (SEE N.F.G.C.)
EXHAUST TERMINAL: BWF061 - BWF162 BWF195,BWF229 (using 4" Pipe) BWF195,BWF229 (using 3" Pipe)	90 ELBOW, TEE, OR VH-1 TERM. 90 ELBOW OR TEE	BY VENT MFR. (TABLE 6)	LISTED CHIMNEY CAP
CATEGORY I VENT KIT: BWF061 - BWF128 BWF162 - BWF229	N/A	N/A	CROWN # 650140 CROWN # 650141

(*) FLEX-L-INTL STAR-34, ZFLEX SVE SERIES III, HEAT FAB SAF-T VENT, PROTECH SYSTEMS FASNSEAL

The following instructions describe the design and installation of Horizontal and Vertical Direct Exhaust (Category III) systems only. Instructions for Chimney (Category I) venting are provided with the Crown Category I vent kit or are available from Crown.

Horizontal Vent System Design

- 1) See Figure 8 for the general horizontal exhaust configuration. For the purposes of this manual, a “horizontal exhaust system” is one that exits the structure through a wall.
- 2) Approved Systems – Use one of these four approved vent systems:
 - Flex-L-International *Star-34*
 - Z-FLEX *SVE Series III* (“Z-Vent II”)
 - Heat Fab *Saf-T Vent*
 - ProTech Systems *FasNSeal*
- 3) Vent Pipe Size:
 - BWF061 to BWF162– 3”
 - BWF-195, BWF-229 –3” or 4”
- 4) Maximum Vent Pipe Length:
 - BWF061 to BWF162: 45 ft + (1) 90 degree elbow + terminal
 - BWF195 to BWF229 (using 4” vent pipe): 45 ft + (1) 90 degree elbow + terminal
 - BWF195 to BWF229 (using 3” vent pipe): 30 ft + (1) 90 degree elbow + terminal
 - Reduce the maximum straight pipe run by the equivalent length from Table 4 for each additional elbow.

Example:

A vent system is planned for a BWF162 which has the following components:

- 2 ft vertical pipe*
- 1 90 elbow*
- 5 ft horizontal pipe*
- 1 90 elbow*
- 3 ft horizontal pipe*
- 1 45 elbow*
- 4 ft horizontal pipe*
- 1 termination elbow*

Since the boiler is a BWF162, all piping must be done in 3” pipe. The first 90 degree elbow and the termination elbow are not considered. From Table 4, the equivalent length of the 3” 45 elbow is 4.5ft. The equivalent length of the 3” 90 degree elbow is 5.5ft. The maximum allowable run of straight pipe on this system is therefore:

$$45ft - 4.5ft - 5.5ft = 35ft$$

Since the planned installation has only 14 ft of straight pipe, the planned vent system length is acceptable

TABLE 4: VENT SYSTEM ELBOW EQUIVALENT LENGTHS

FITTING	NOMINAL SIZE	
	3 INCH	4 INCH
90 DEG. ELBOW	5.5	8
45 DEG. ELBOW	4.5	4.5

HORIZONTAL CONDENSATE TEE TREATED AS STRAIGHT PIPE

- 5) Minimum Vent Pipe Length: 2 ft + (1) 90 degree elbow + terminal
- 6) Permitted Terminals:
 - Choice of Tjernlund VH1 series terminal, a 90-degree elbow with rodent screen, or a termination tee with a rodent screen. The Tjernlund VH1 terminals may not be used on BWF195s and BWF 229s when they are vented with 3" pipe. If the Tjernlund terminal is used, select one of the following:
 - BWF061 to BWF162: Tjernlund VH1-3 (Crown #50-032) 3" terminal
 - BWF195, BWF229: Tjernlund VH1-4 (Crown #50-042) 4" terminal
 - If an elbow or tee is used for the vent termination, it must be of the same type and manufacture as the rest of the vent system.
 - If a tee is used for the termination it must be installed with the run of the Tee vertical.
- 7) Wall thimbles – Wall thimbles are required where the vent pipe passes through combustible walls with less than a 5" clearance. Use the appropriate wall thimble shown in Table 5.
- 8) Pitch of horizontal piping – A 1/4" per foot pitch towards the outside is preferred. Alternatively, the horizontal piping may be pitched 1/4" per foot towards the boiler, however a condensate trap is required. See (9).

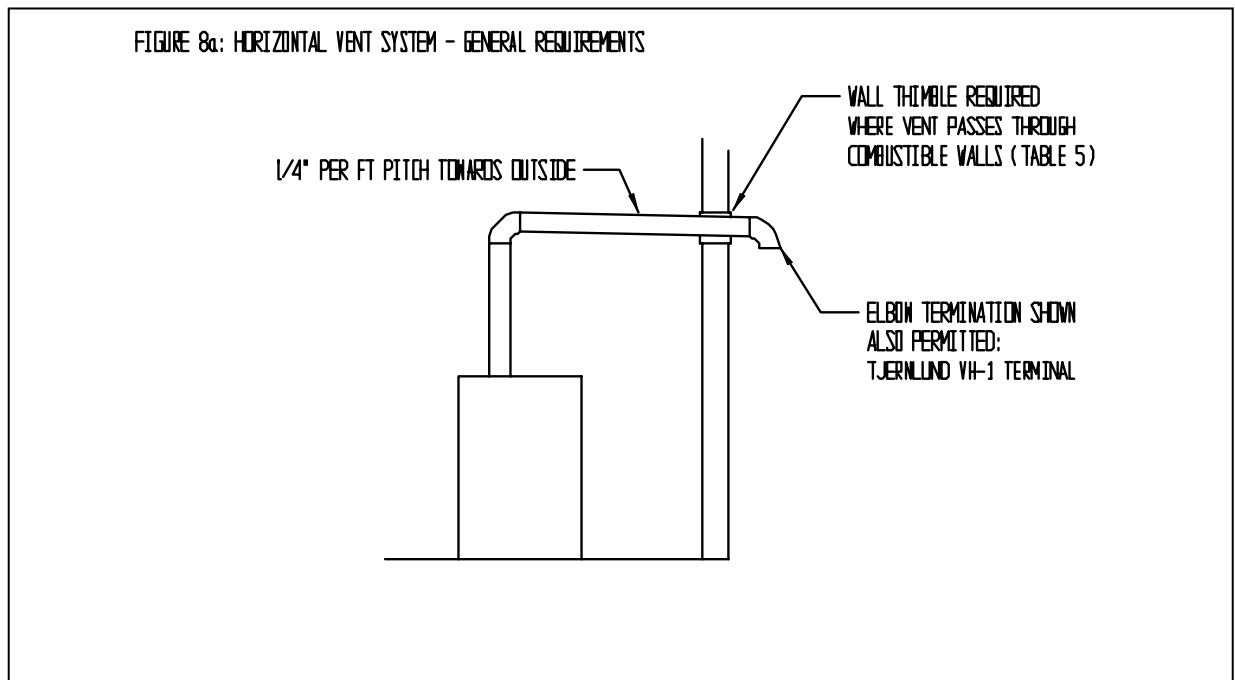

- 9) Condensate traps –In some horizontal installations, condensate traps may be needed to prevent condensate from running into the boiler or collecting in the vent system. A condensate trap must be used if the horizontal piping does not have a continuous slope to the outside. If this is the case, put a trap in the lowest section of horizontal piping (Fig 8b).
- 10) Use only a “horizontal” type condensate Tee (Fig 9).
- 11) Vertical and horizontal sections of piping must be properly supported. See the “Vent System Assembly” section of this manual for more information.

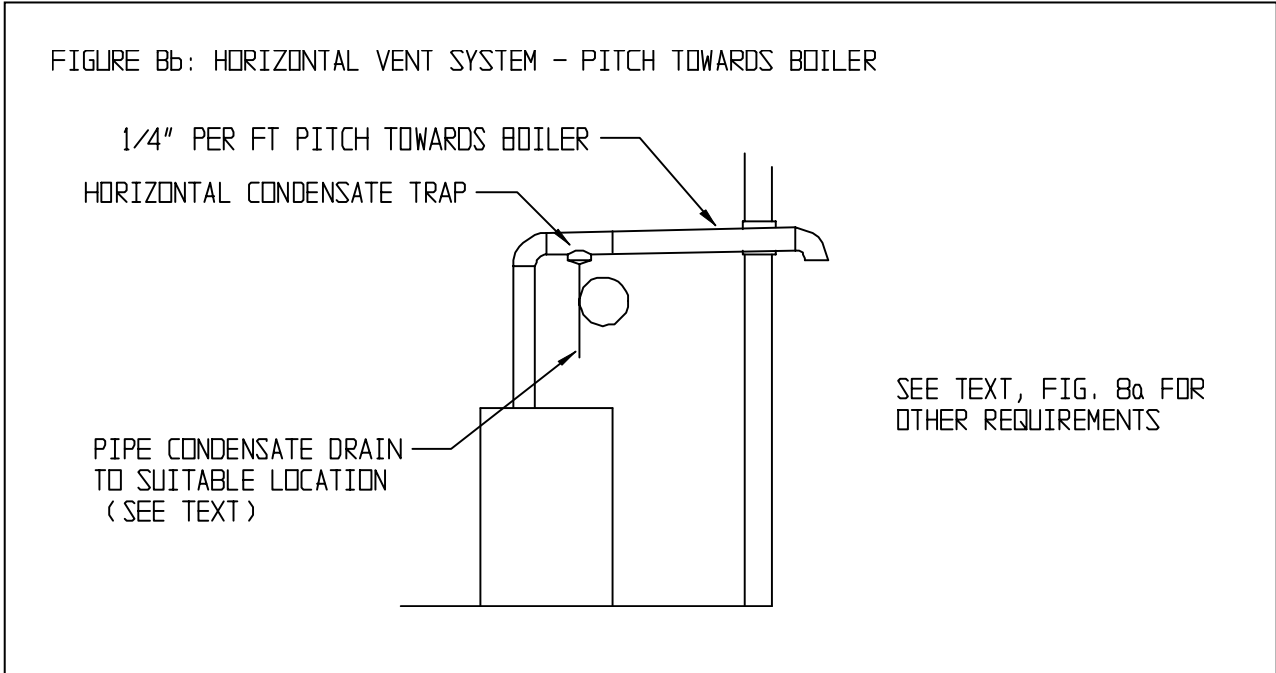

12) Location of Horizontal Vent Terminal – Observe the following limitations on the terminal location:

- Terminal must be at least 4 feet below or 4 feet horizontally from any window, door, or gravity air inlet into the building (Fig. 10).
- The bottom of the terminal must be at least 12" above the normal snow line. In no case should it be less than 12" above grade level (Fig 10).
- The bottom of the terminal must be at least 7 feet above a public walkway.
- The bottom of the terminal must be at least 3 feet above any forced air inlet located within 10 feet.
- A clearance of at least 4 feet horizontally or 4 feet vertically must be maintained between the terminal and gas meters, electric meters, regulators, and relief equipment.
- Do not locate the terminal under decks or similar structures.
- Top of terminal must be at least 4 feet below eaves, soffits, or overhangs. Overhang may not exceed 3 feet (Fig. 12). Do not use the Tee terminal under an overhang deeper than 6".
- Terminal must be at least 3 feet from an inside corner.
- Under certain conditions, water in the flue gas may condense on the structure in areas around the terminal. If these areas are made of materials subject to damage by flue gas condensate, they should be protected.
- If possible, install the terminal on a wall away from the prevailing wind. Reliable operation of this boiler cannot be guaranteed if the terminal is subjected to winds in excess of 40 mph.
- The noise level in the vicinity of the terminal is approximately 65 dB (roughly the level of a normal conversation). Care should be taken when the terminal is positioned in areas where this might be objectionable, such as near bedroom windows.

TABLE 5: WALL THIMBLES

VENT SYSTEM	VENT MANUFACTURER'S PART #	
	3 INCH	4 INCH
FLEX-L-INTL STAR-34	SRWT-03	SRWT-04
Z-FLEX SVE SERIES III	2SVSWTF03	2SVSWTF04
HEAT FAB SAF-T VENT	7393GC	7493GC
PROTECH SYSTEMS FASNSEAL	FSWT3	FSWT4

FIGURE 9: CONDENSATE TRAPS

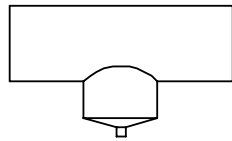

HORIZONTAL TRAP - ACCEPTABLE

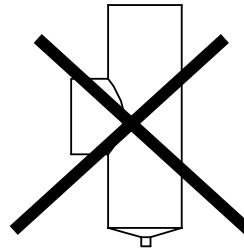

DO NOT USE VERTICAL TRAP

FIGURE 10a: LOCATION OF VENT TERMINAL RELATIVE TO WINDOWS, DOORS, GRAVITY OPENINGS, AND GRADE

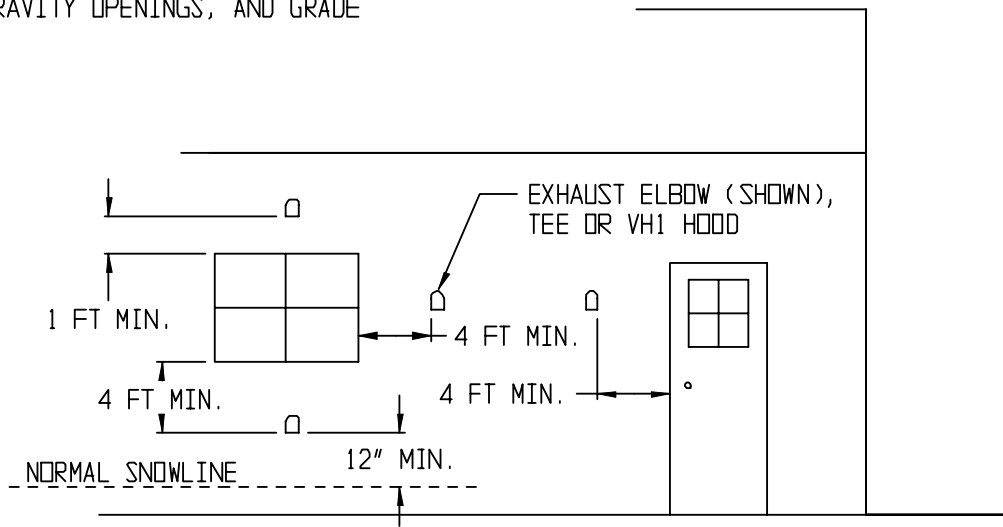
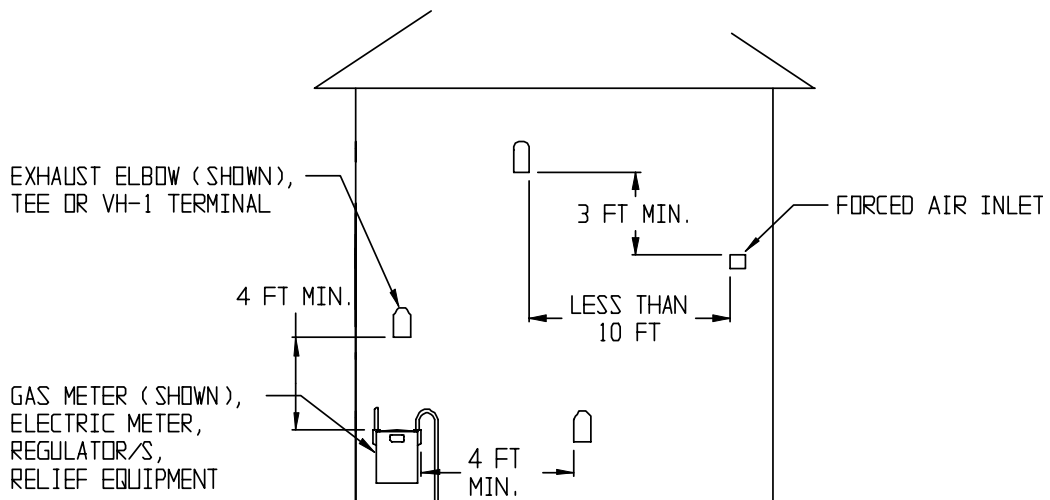
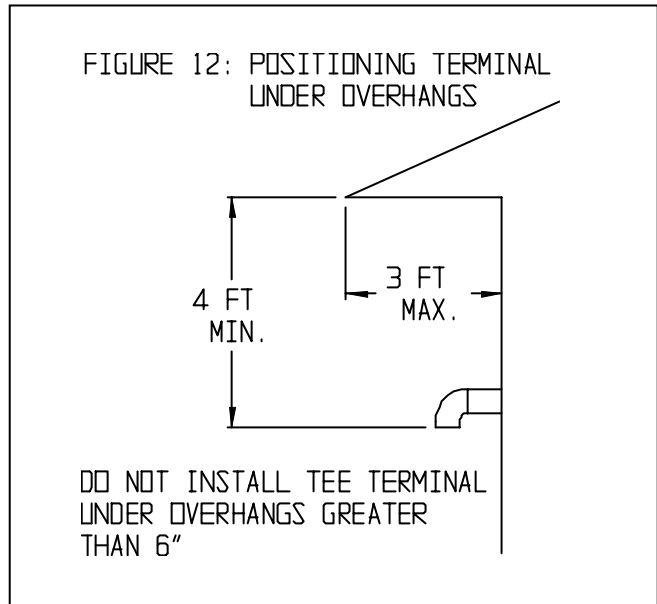
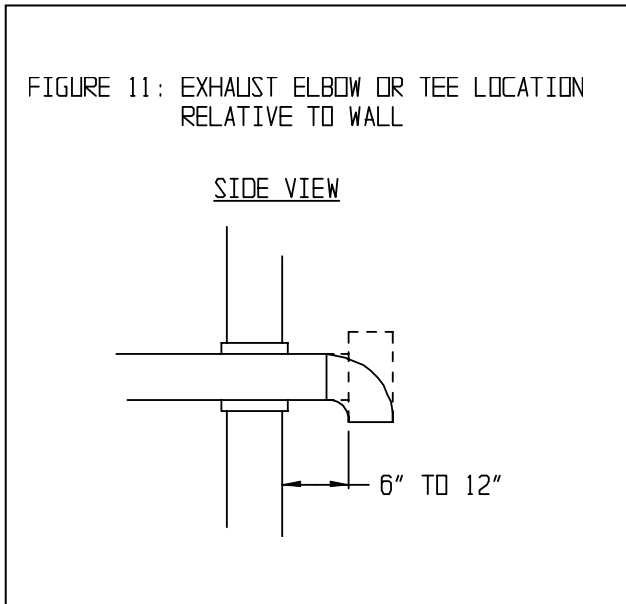

FIGURE 10b: LOCATION OF VENT TERMINAL RELATIVE TO METERS AND FORCED AIR INLETS





Vertical Vent System Design

- 1) See Figure 13 for the general vertical stainless steel venting configuration. For the purposes of this manual, a “vertical exhaust system” is a Category III vent system that exits the structure through a roof.
- 2) Approved Systems – Use one of these four approved vent systems:
 - Flex-L-International *Star-34*
 - Z-FLEX *SVE Series III* (“Z-Vent III”)
 - Heat Fab *Saf-T Vent*
 - ProTech Systems *FasNSeal*
- 3) Vent Pipe Size:
 - BWF061 to BWF162 – 3”
 - BWF195, BWF229 – 4”

TABLE 6: CAPS FOR VERTICAL VENT SYSTEMS

VENT SYSTEM	VENT MANUFACTURER'S PART #	
	3 INCH	4 INCH
FLEX-L-INTL <i>STAR-34</i>	SRRC-03	SRRC-04
Z-FLEX <i>SVE SERIES III</i>	2SVSRCF03	2SVSRCF04
HEAT FAB <i>SAF-T VENT</i>	5300CI	5400CI
PROTECH SYSTEMS <i>FASNSEAL</i>	FSRC3	FSRC4

4) Maximum Vent Pipe Length:

- BWF061 to BWF162 – 39.5 ft + (2) 90 degree elbows + cap
- BWF195, BWF229 (using 4” vent pipe): 37 ft + (2) 90 degree elbows + cap
- BWF195, BWF229 (using 3” vent pipe): 24.5 ft + (2) 90 degree elbows + cap
- Reduce the above maximum straight pipe runs by the equivalent length from Table 4 for each additional elbow beyond the first two.

Example:

A vertical vent system is planned for a BWF162 that has the following components:

*2 ft vertical pipe
1 90 Elbow
1 condensate trap which has an 18 inch long run
1 90 Elbow
1 ft vertical pipe
1 45 elbow
2 ft sloped pipe
1 45 elbow
7 ft vertical pipe
1 Cap*

Since the boiler is a BWF162, all piping must be done in 3” pipe. The first two 90 elbows and the termination cap are not considered. The condensate trap is treated as a straight length of pipe 1.5 feet in length. The result is 13.5 ft of straight pipe and two 45 elbows. From Table 4, the equivalent length of the 45 elbow is 4.5ft. The maximum allowable run of straight pipe on this system is therefore:

$$37.5 \text{ ft} - 4.5 \text{ ft} - 4.5 \text{ ft} = 28.5 \text{ ft}$$

Since the planned installation has 13.5 ft of straight pipe, the planned vent length is within the maximum limit.

- 5) Minimum Vent Pipe Length - 6 ft + (2) 90 degree elbows + cap
- 6) Permitted Terminals – A cap must be used which is compatible with the rest of the vent system. See Table 6 for the appropriate cap.
- 7) Condensate traps – A condensate trap is required on all vertical-venting systems. Install this trap as shown in Figure 13. If there are additional sections of horizontal piping in the vent system, they must either be equipped with their own condensate Tees or pitched so that condensate will run into the one required trap.
- 8) Use only a “horizontal” type condensate Tee (Fig. 9).
- 9) Pitch of horizontal piping – Pitch the lowest horizontal section of piping ¼” per foot towards the boiler. Other horizontal sections (if any) must be pitched so that condensate will run towards a condensate Tee.
- 10) Fire-stops and wall thimbles – A wall thimble is required where the exhaust pipe passes through combustible walls with less than a 5” clearance. Firestops are required where the vent passes through ceilings. These components must be compatible with the rest of the exhaust system. Table 5 shows wall thimble model numbers for the approved vent systems. Table 7 shows firestop model numbers for the approved vent systems.

- 11) Piping supports – Vertical and horizontal sections of piping must be properly supported. See the “Vent System Assembly” section of this manual for more information.
- 12) Location of vent cap– The lowest discharge opening on the cap must be at least 2 feet above any object located within 10 feet (Fig. 14):

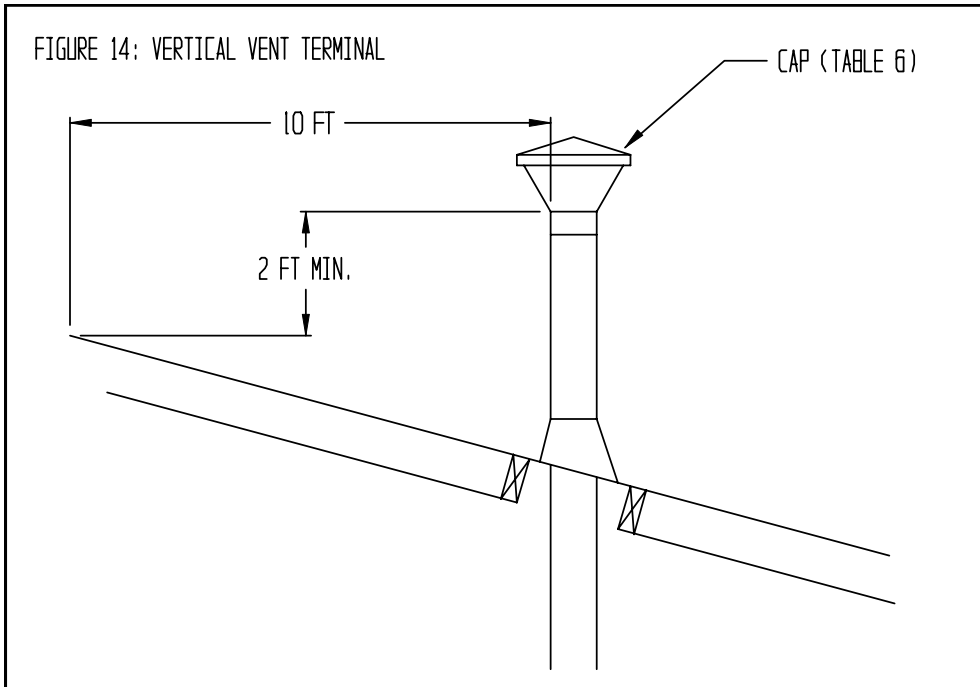
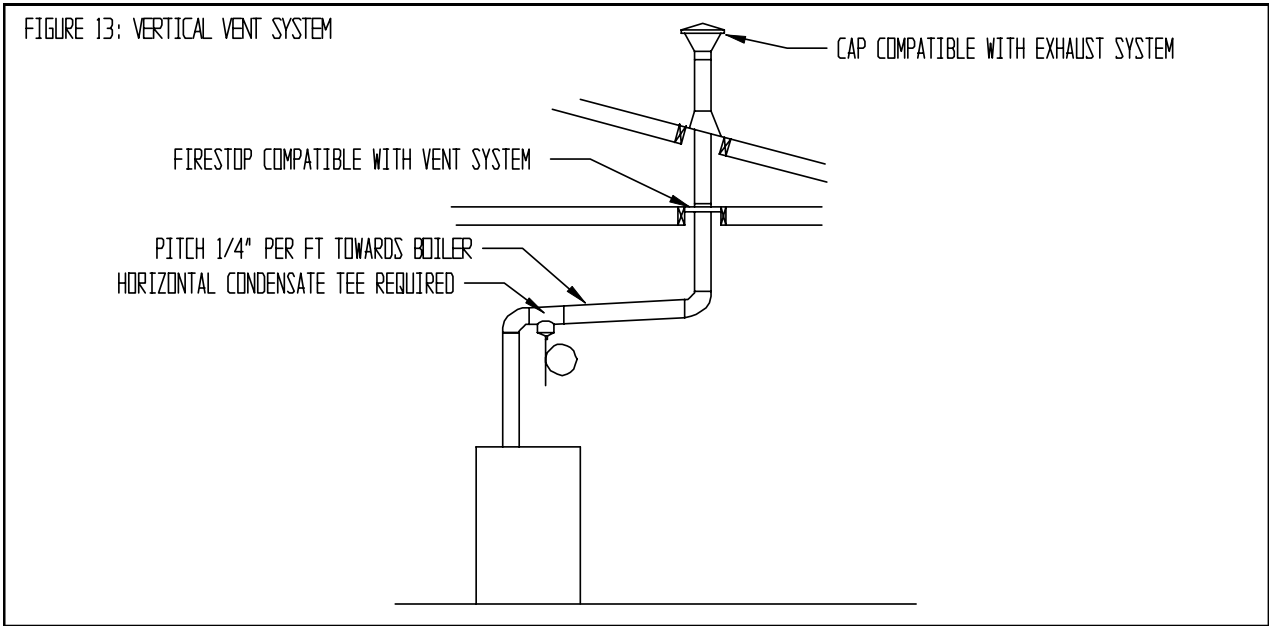

TABLE 7: FIRESTOPS FOR VERTICAL VENT SYSTEMS

VENT SYSTEM	VENT MANUFACTURER'S PART #	
	3 INCH	4 INCH
FLEX-L-INTL STAR-34	SRFS03	SRFS04
Z-FLEX SVE SERIES III (SUPPORT)	2SVSFSSF03	2SVSFSSF04
Z-FLEX SVE SERIES III (SPACER)	2SVSFSF03	2SVSFSF04
HEAT FAB SAF-T VENT	7373GC	7473GC
PROTECH SYSTEMS FASNSEAL	FSFS3	FSFS4

Removing an Existing Boiler From a Common Chimney

In some cases, when an existing boiler is removed from a common chimney, the common venting system may be too large for the remaining appliances. At the time of removal of an existing boiler, the following steps shall be followed with each appliance remaining connected to the common venting system placed in operation, while the other appliances remaining connected to the common venting system are not in operation.

- (a) Seal any unused openings in the common venting system.
- (b) Visually inspect the venting system for proper size and horizontal pitch and determine there is no blockage or restriction, leakage, corrosion and other deficiencies which could cause an unsafe condition.
- (c) Insofar as practical, close all building doors and windows and all doors between the space in which all the appliances remaining connected to the common venting system are located and other spaces of the building. Turn on clothes dryers and any appliance not connected to the common venting system. Turn on any exhaust fans, such as range hoods and bathroom exhausts, so they will operate at maximum speed. Do not operate a summer exhaust fan. Close fireplace dampers.
- (d) Place in operation the appliance being inspected. Follow the lighting instructions. Adjust thermostat so the appliance will operate continuously.
- (e) Test for spillage at the draft hood relief opening after 5 minutes of main burner operation. Use the flame of a match or candle, or smoke from a cigarette, cigar, or pipe.
- (f) After it has been determined that each appliance remaining connected to the common venting system properly vents when tested as outlined above, return doors, windows, exhaust fans, fireplace dampers and any other gas-burning appliances to their previous condition of use.
- (g) Any improper operation of the common venting system should be corrected so the installation conforms with the National Fuel Gas Code, ANSI Z223.1. When resizing any portion of the common venting system, the common venting system should be resized to approach the minimum size as determined using the appropriate tables in Part 11 of the National Fuel Gas Code, ANSI Z223.1.

Vent System Assembly

1) General Assembly Notes:

a) Where the use of “silicone” is called for in the following instructions, use only the following sealants:

- Flex-L-International *Star-34* – GE RTV106 or GE IS806
- Z-FLEX *SVE Series III* (“Z-Vent III”) – Silicone not required for joints between pipe sections.
- Heat Fab *Saf-T Vent* – GE RTV 106
- ProTech Systems *FasNSeal* - Silicone not required for joints between pipe sections.
- Use the same silicone used to seal vent pipe sections to seal the boiler vent collar and the Tjernlund VH-1 terminal (if used). For ProTech *FasNSeal* or Z-Flex *Z-Vent III*, use GE RTV 106 for the vent collar and Tjernlund terminal.

b) Longitudinal welded seams should not be placed at the bottom of horizontal sections of vent pipe.

c) Do not drill holes in vent pipe.

d) Do not attempt to mix vent components of different vent system manufacturers.

2) Vent Collar Installation – The vent collar is shipped loose in the accessory bag along with two collar gaskets, the outlet orifice, and four 10-32 mounting screws. The outlet orifice will be marked with either the boiler model number or a Crown part number for the orifice. Verify that the number marked on the outlet exhaust orifice matches that of either the boiler model number or the part number shown in the chart in Figure 15. Mount the collar and orifice as shown in Figure 15. If desired, the first piece of exhaust pipe can be connected to the collar before mounting the collar on the boiler.

3) Tjernlund VH-1 terminal Installation – If the Tjernlund VH-1 terminal is used, follow the instructions provided with the terminal to mount it in the wall. This terminal may be installed in direct contact with combustible construction.

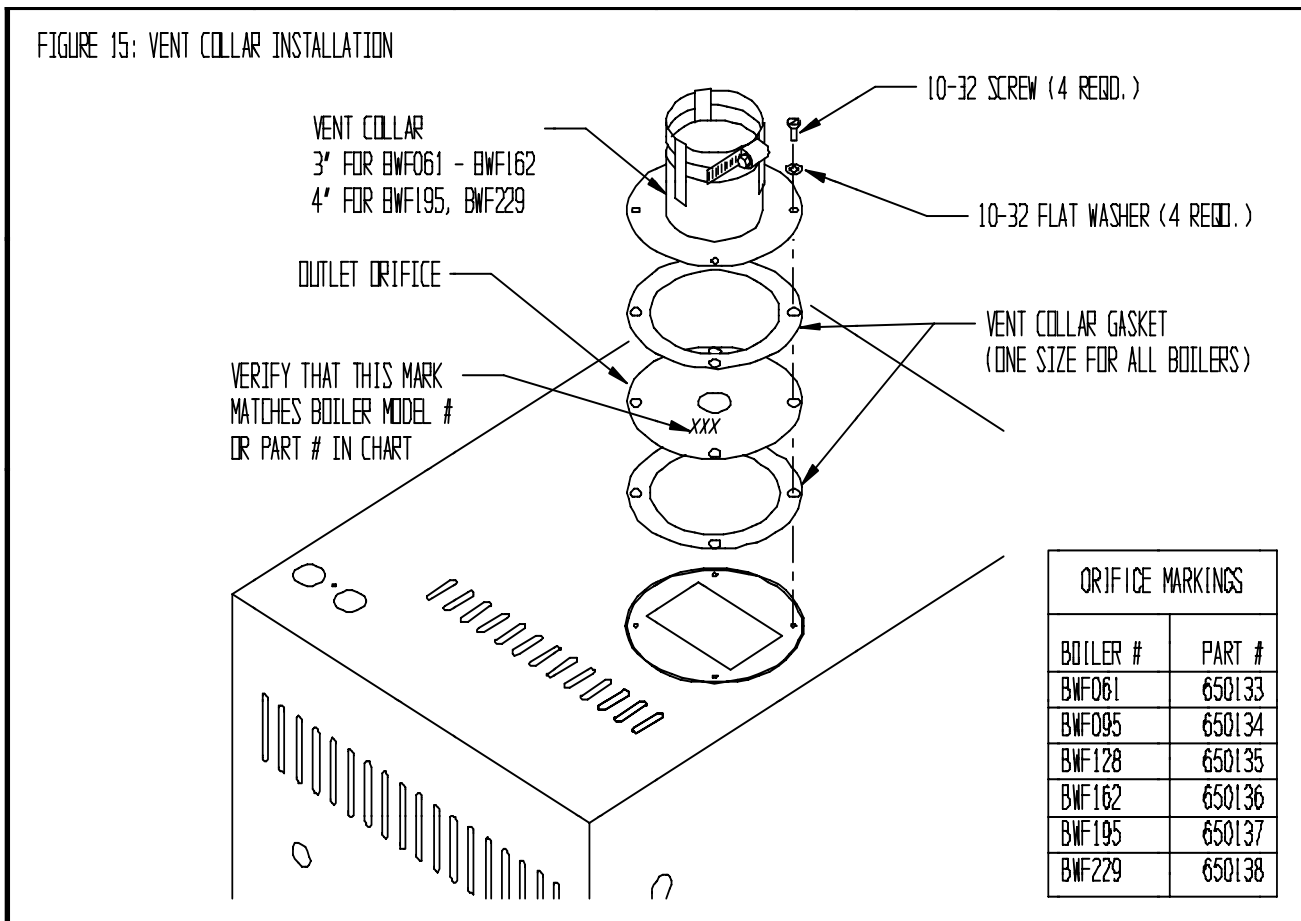

4) Assembly of Flex-L-Intl. Star-34 Vent System:

a) Star-34 General Notes:

- Do not cut Star-34 vent components.
 - Support horizontal piping sections at intervals of 48" or less.
 - Vertical venting systems must be supported by at least one Star-34 Firestop. An additional vertical support is required after any offset.
 - Orient Star-34 components so that the arrows on the piping labels are in the direction of flue gas flow.
- b) Start assembly of the vent system at the boiler. Remove the hose clamp shipped on the BWF vent collar. Bend the three hose clamp tabs on this collar outward slightly.
- c) Clean the exterior of the male end of the first piece of pipe and the inside of the vent collar on the boiler. Use a cleaner such as Methyl Ethyl Keytone (MEK) or naptha.
- d) On the male end of the pipe, apply a 1/4" wide bead of silicone approximately 1/4" from the end of the pipe and another 1/4" bead against the joint side of the stop bead (Fig 17).
- e) Insert the male end of the pipe into the boiler vent collar until it bottoms out.
- f) Apply an additional bead of silicone over the outside of the joint and smooth out. Also apply silicone over the seams in the vent collar (Fig 17).
- g) Replace and tighten the clamp on the vent collar.
- h) Clean the female end of the first piece of pipe. Also clean the male end of the next piece of pipe.
- i) Apply silicone as in step (d) (Fig 18).
- j) Align the longitudinal seams of the pipe and insert the male end of the second pipe into the female end of the first pipe.
- k) Insert a StaR joiner band into the inlet of the beaded channel. Feed the joiner band in so that it makes its way around the channel and overlaps by approximately 1/2" (Fig 18).
- l) Cut the excess joiner band so that it lays flat in the beaded channel (Fig 18).
- m) Fill the inlet of the beaded channel with silicone. Smooth the silicone over the channel inlet as well as the silicone between the female end and the stop bead of the male end (Fig 18).
- n) Repeat Steps (h) – (m) for the remaining Star-34 components. If a termination elbow or tee is used, use this procedure to complete the exhaust system.
- o) To connect Star-34 to the VH-1 terminal, the vent system must be configured so that the female end of the last piece of Star-34 will fit over the vent connection on the terminal. Before permanently making this joint, clean both the male end of the terminal and the female end of the last piece of pipe with Methyl Ethyl Keytone or Naptha. Apply a 1/4 inch bead of silicone 1/4" from the male end of the terminal. Also apply a 1/4" bead of silicone along the weld seam on the inside of the female section of the Star-34 pipe. Slip the female end of the vent pipe over the male end of the terminal until it is over at least 1 1/4 inches of the terminal. Apply a second bead of silicone over the joint between the vent pipe and the terminal as well as over the channel inlet. Do not attempt to use a locking band at this joint. Install a pipe support or other means to prevent the Star-34 pipe from separating from the terminal.
- p) Allow the silicone to cure for 24 hours before operating the boiler.

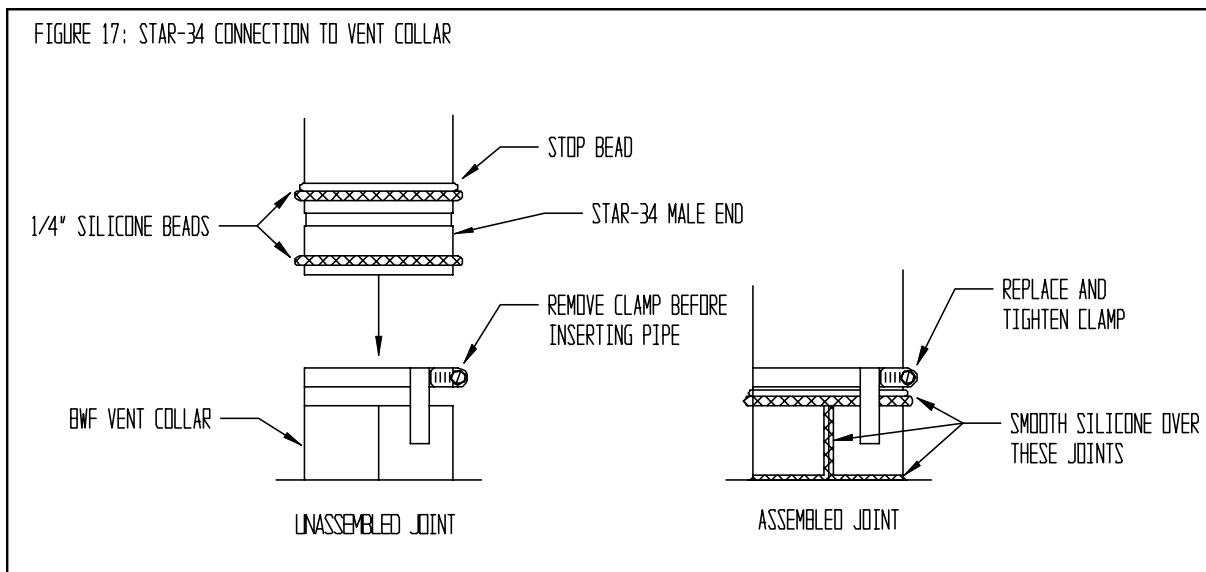

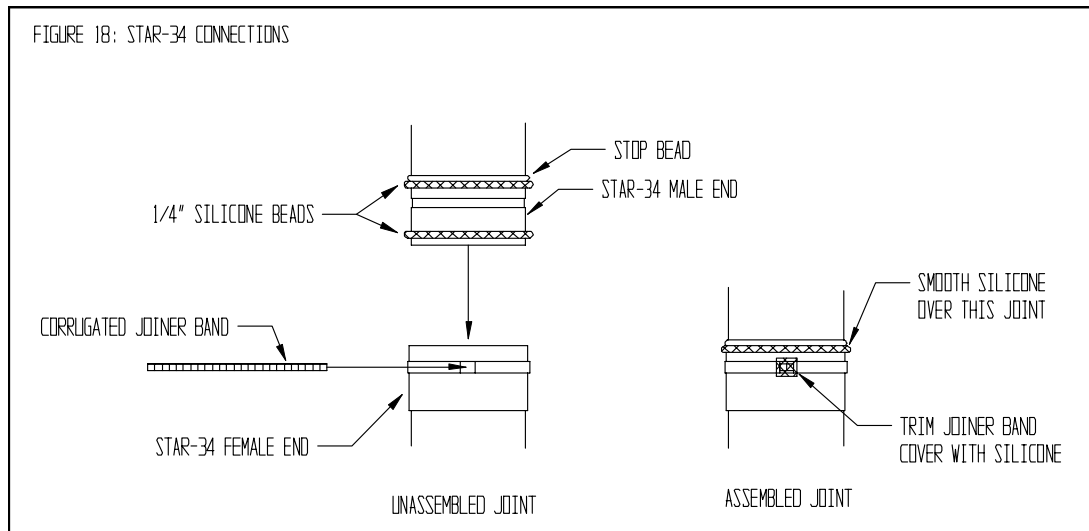

5) Assembly of Z-Flex SVE Series III:

a) SVE Series III General Notes:

- Non-expanded ends of SVE Series II piping sections may be cut using aviation snips or a 24 thread per inch hacksaw. File or sand the cut end smooth before assembling. Expanded ends may be cut to adapt the SVE Series III to the vent collar or VH-1 terminal. See the instructions below.
- Support horizontal piping sections at intervals of 48" or less.
- Vertical venting systems must be supported in at least one point inside the structure using a Z-Flex Fire Stop Support or Guy Band. An additional vertical support is required after any offset.

- b) Start assembly of the vent system at the boiler. Remove the hose clamp shipped on the BWF vent collar. Bend the three hose clamp tabs on this collar outward slightly.
- c) Clean the exterior of the male end of the first piece of pipe and the inside of the vent collar on the boiler. Remove dirt, grease, and moisture from the surfaces to be sealed. Dry surfaces or allow to dry thoroughly.
- d) On the male end of the pipe, apply a 1/4" wide bead of high temperature silicone approximately 1/2 inch from the male end of the pipe. Apply 1/4" beads of silicone along both sides of the longitudinal seam (Fig. 19).
- e) Insert the male end of the pipe into the boiler vent collar until it bottoms out.
- f) Apply an additional bead of silicone over the outside of the joint and smooth out. Also apply silicone over the seams in the collar (Fig 19).
- g) Replace and tighten the clamp on the vent collar.
- h) All other joints in the SVE Series III venting system rely on a gasket in the female end of the pipe for a proper seal.

CAUTION

- MAKE SURE THAT GASKET IS IN POSITION AND UNDAMAGED IN THE FEMALE END OF THE PIPE.
- MAKE SURE THAT BOTH THE MALE AND FEMALE PIPES ARE FREE OF DAMAGE PRIOR TO ASSEMBLY.
- IF MALE END OF PIPE IS CUT, IT MUST BE SQUARE AND CAREFULLY DEBURRED PRIOR TO ASSEMBLY.

- i) Align the longitudinal seams of the pipe. Insert the male end of the second pipe into the female end of the first pipe as far as it will go (at least 1.75 inches). See Figure 20.
- j) Tighten the locking band with a nut driver to a torque of between 40 in-lbs and 50 in-lbs.
- k) Repeat Steps (i) and (j) for the remaining SVE Series III components. If a termination elbow is used, use this procedure to complete the exhaust system.

- l) If a termination elbow or tee is used, a locking band or gear clamp must be used at either side of the wall penetration to prevent shifting of the vent system in and out of the wall.
- m) To join SVE Series III to the VH-1 terminal, cut off the female end of the pipe that is to be joined to the terminal. When making this cut, make sure that it will be possible to insert the cut end of the pipe at least one inch inside the terminal. Remove any oil, grease, or moisture from the exterior of the SVE Series III pipe and the female end of the terminal. On the male end of the pipe, apply a 1/4" wide bead of high temperature silicone approximately 1/2 inch from the male end of the pipe. Apply 1/4" beads of silicone along both sides of the longitudinal seam (Fig. 19). Insert this end of the pipe into the terminal connection with at least a 1" overlap. It may be necessary to crimp the end of the vent pipe before it can be inserted into the terminal. Apply an additional bead of silicone over the outside of the joint. Smooth out the excess silicone. Use one of the following Z-Flex locking bands to mechanically secure the vent pipe to the terminal:

<u>SVE Series III Nominal Size</u>	<u>Z-Flex #</u>
3"	2SVSLBF03
4"	2SVSLBF04

- n) Allow the silicone to cure for 24 hours before operating the boiler.

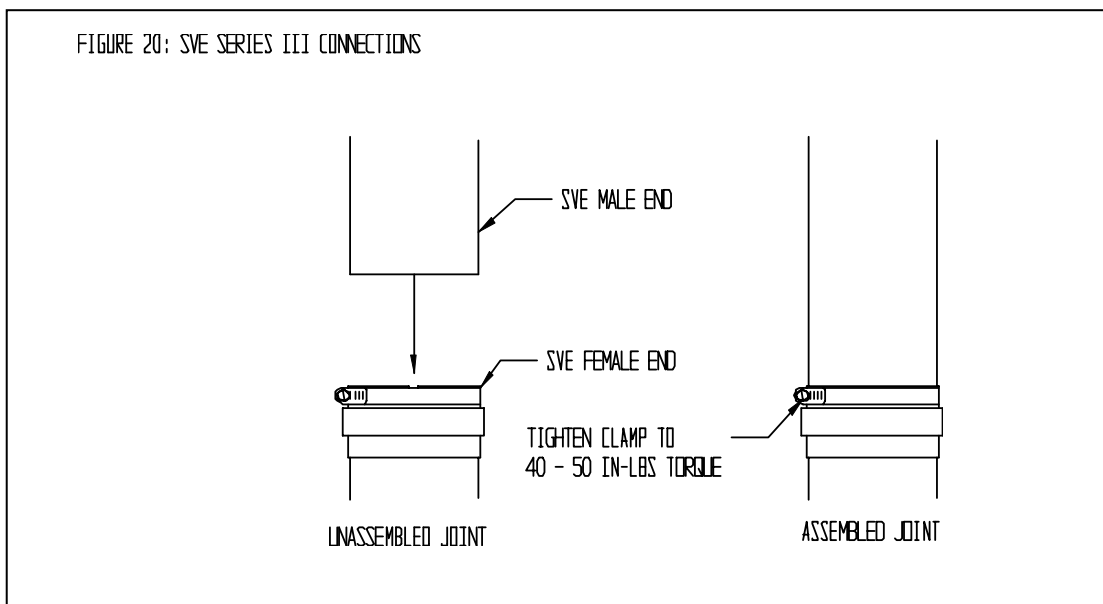
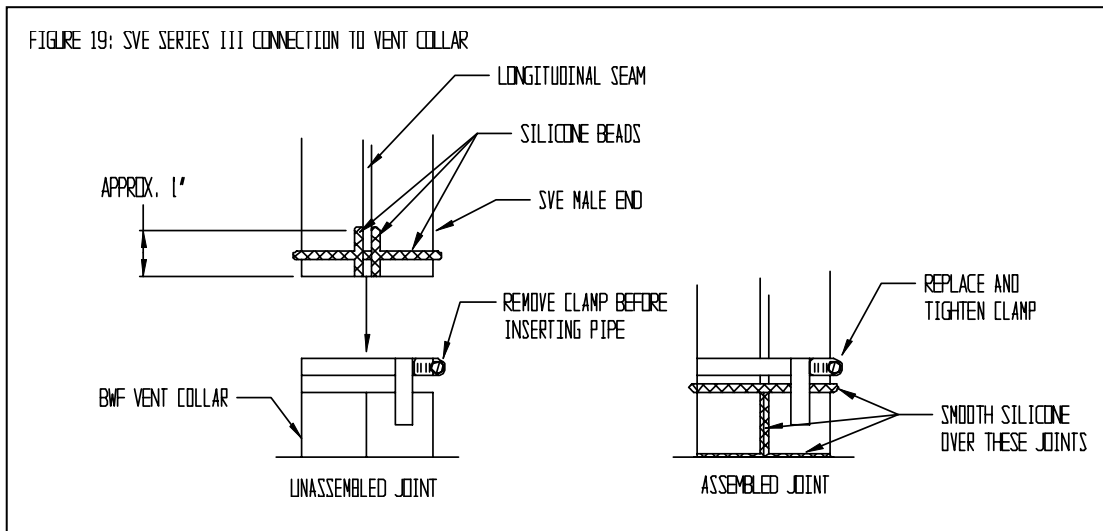

6) Assembly of Heat Fab Saf-T Vent:

a) Saf-T Vent General Notes:

- In general, Saf-T Vent pipe sections may not be cut. Exceptions to this are the Saf-T vent slip connector and connections to the boiler vent collar and the VH-1 terminal. In these cases, use a sharp pair of aviation snips, an abrasive cut-off, or a plasma cutter. See the Saf-T Vent instructions for information on cutting the slip connector.
- Orient Saf-T Vent components so that the arrows on the piping labels are in the direction of flue gas flow.
- Support horizontal piping sections at intervals of 6 feet or less.
- Vertical venting systems must be supported by at least one Heat Fab support. An additional vertical support is required after any offset.

- b) Start assembly of the vent system at the boiler. Remove the hose clamp shipped on the CSC vent collar. Bend the three hose clamp tabs on this collar outward slightly.
- c) Cut the male “spigot” off of the first piece of pipe (Fig 21). If necessary, crimp the cut end of the pipe so that it can be inserted at least 1” into the collar.
- d) Clean the exterior of the male end of the first piece of pipe and the inside of the vent collar on the boiler with an alcohol pad.
- e) On the male end of the pipe, apply a ¼” wide bead of high temperature silicone approximately ½ inch from the male end of the pipe. Also apply a ¼” bead of silicone along the first 2 ½” of the longitudinal weld.
- f) Insert the male end of the pipe into the boiler vent collar until it bottoms out.
- g) Apply an additional bead of silicone over the outside of the joint and smooth out (Fig 21). Also apply silicone over the seams in the vent collar.
- h) Replace and tighten the clamp on the vent collar.
- i) Clean the male end of the next piece of pipe. Also clean the female end of the first piece of pipe.
- j) Apply a ¼” bead of silicone around the male end of the second piece of pipe between ¼” and 3/8” from the end of the pipe. Also run a ¼” bead of silicone along the longitudinal welded seam from the end of the pipe to the top of the spigot (Fig 22).
- k) Align the longitudinal seams of the pipe and insert the male end of the second pipe into the female end of the first pipe until it bottoms out.
- l) With a moistened finger or flat tool, spread out any silicone that oozes out of the joint.
- m) Bend the locking tabs over the locking ring as shown in Figure 22.
- n) Apply silicone over any visible voids around the joint and smooth it into any crevices.
- o) Repeat Steps (i) – (n) for the remaining Saf-T-Vent components. If a termination elbow or tee is used, use this procedure to complete the exhaust system.
- q) To join Saf-T Vent to a VH-1 terminal, cut the locking tabs off of the female end of the Saf-T Vent pipe to be joined to the terminal. Apply a ¼” bead of silicone around the terminal connection about ¼” from the end. Slip the Saf-T Vent pipe over the terminal and apply a second bead of silicone over the joint. Smooth the excess silicone over the joint, making sure that there are no visible voids in the silicone. Install a pipe support or other means to prevent the Saf-T Vent pipe from separating from the terminal.
- p) Allow the silicone to cure for 24 hours before operating the boiler.

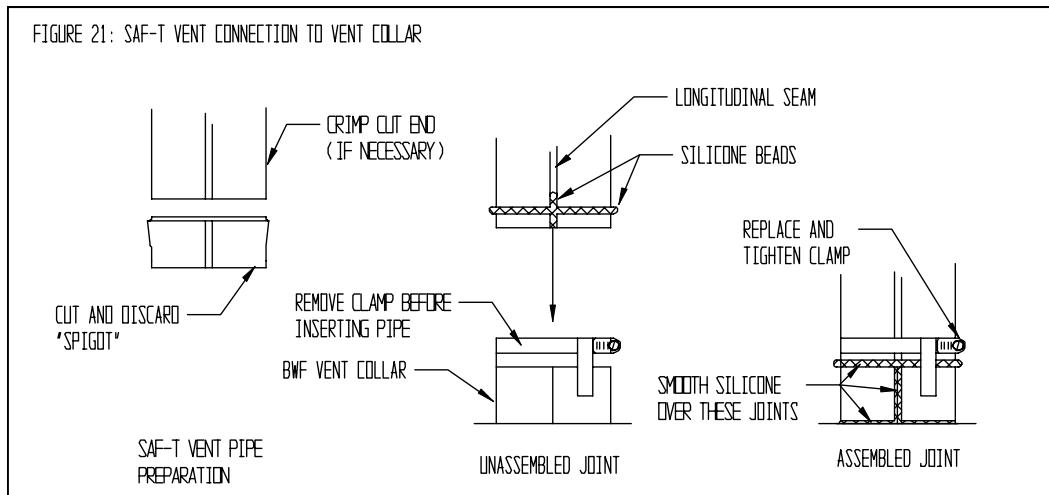

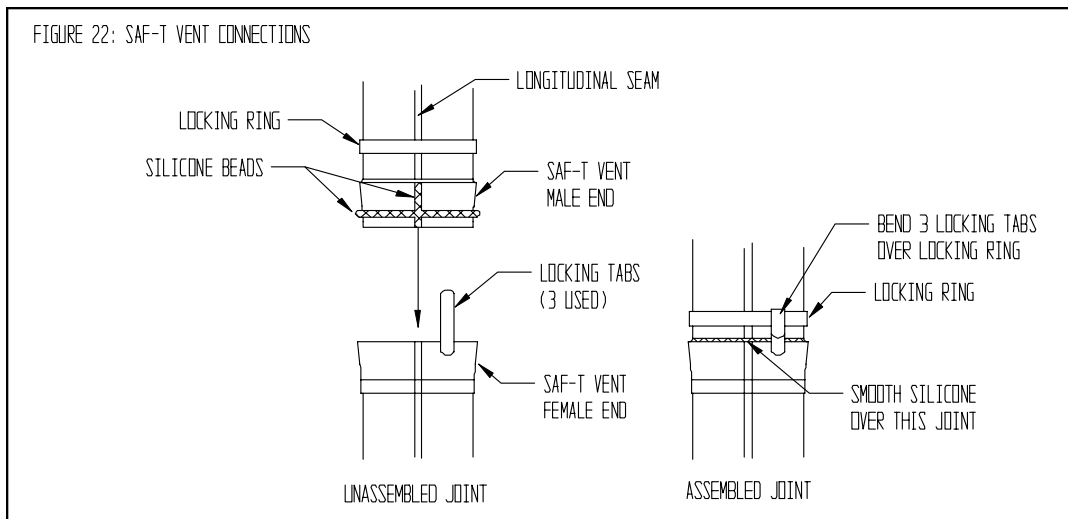

7) Assembly of Protech FasNSeal:

a) FasNSeal General Notes:

- Do not cut 4" FasNSeal pipe. The male end of 3" FasNSeal may be cut. Cut must be square to ensure a proper seal.
- Orient FasNSeal vent components so that the arrows on the piping labels are in the direction of flue gas flow.
- Support horizontal piping sections at intervals of 6 feet or less.
- Vertical venting systems must be supported by at least one FasNSeal support. An additional vertical support is required after any offset.

- b) Start assembly of the vent system at the boiler. Remove the hose clamp shipped on the BWF vent collar. Bend the three hose clamp tabs on this collar outward slightly.
- c) Clean the exterior of the male end of the first piece of pipe and the inside of the vent collar on the boiler. Remove dirt, grease, and moisture from the surfaces to be sealed. Dry surfaces or allow to dry thoroughly.
- d) On the male end of the pipe, apply a 1/4" wide bead of high temperature silicone approximately 1/4 inch from the male end of the pipe.
- e) Insert the male end of the pipe into the boiler vent collar until it bottoms out.
- f) Apply an additional bead of silicone over the outside of the joint and the seams on the vent collar and smooth out (Fig 23).
- g) Replace and tighten the clamp on the vent collar.
- h) All other joints in the FasNSeal venting system rely on a gasket in the female end of the pipe for a proper seal.

CAUTION

- MAKE SURE THAT GASKET IS IN POSITION AND UNDAMAGED IN THE FEMALE END OF THE PIPE.
- MAKE SURE THAT BOTH THE MALE AND FEMALE PIPES ARE FREE OF DAMAGE PRIOR TO ASSEMBLY.
- IF 3" PIPE IS CUT, CUT END MUST BE SQUARE AND CAREFULLY DEBURRED PRIOR TO ASSEMBLY.

- i) Align the longitudinal seams of the pipe. Insert the male end of the second pipe into the female end of the first pipe until the bead on the male end contacts the flare on the female end (Fig. 24).
- j) Tighten the locking band with a nut driver.
- k) Repeat Steps (i) and (j) for the remaining FasNSeal components. If a termination elbow or tee is used, use this procedure to complete the exhaust system.
- l) To join FasNSeal to a 3" VH-1 terminal, use a Protech FSA-M-3 "Modine Appliance Adapter" (Protech #300444). Apply a 1/4" bead of silicone to the terminal connection about 1/4" from its end. Slip the female end of the adapter over the terminal end so that there is an overlap of at least 1 3/4 inches. Tighten the hose clamp to mechanically lock the pipe onto the terminal. Apply and smooth silicone over the outside of the joint including the hose clamp in the FasNSeal pipe. Connect the female end of the venting system to the male end of the adapter per Steps (i) and (j) above.

- m) To join FasNSeal to a 4" VH-1 terminal slip the female end of the FasNSeal pipe over the terminal connection so there is an overlap of at least 1 3/4". Tighten the hose clamp to mechanically lock the pipe onto the terminal. Apply and smooth silicone over the outside of the joint including the hose clamp in the FasNSeal pipe.
- n) Allow the silicone to cure for 24 hours before operating the boiler.

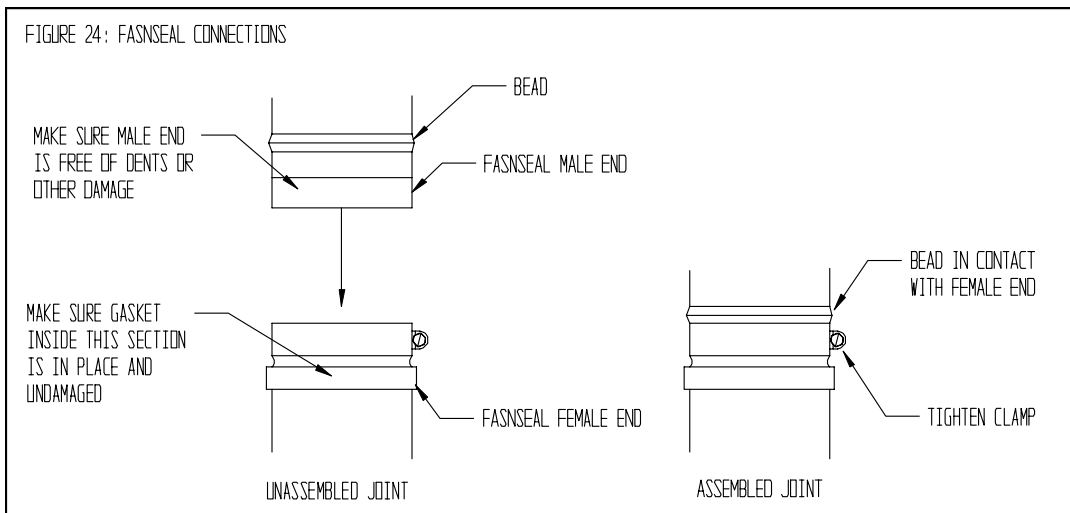
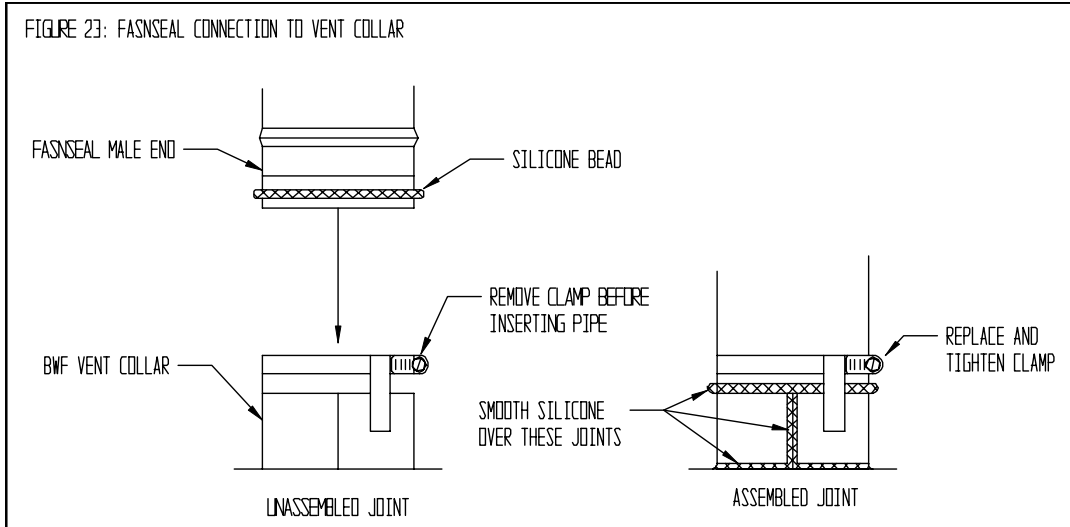

8) Condensate Traps:

- a) Trap should have the basic configuration shown in Figure 25. All tubing is 3/8" I.D.
- b) All drain tubing must be acid resistant.
- c) At least the first 6 inches of tubing must be silicone with a 400F temperature rating.
- d) Pipe condensate to a drain or other suitable location. Make sure that condensate disposal method is in accordance with local regulations. Ensure condensate is not subjected to freezing temperatures.

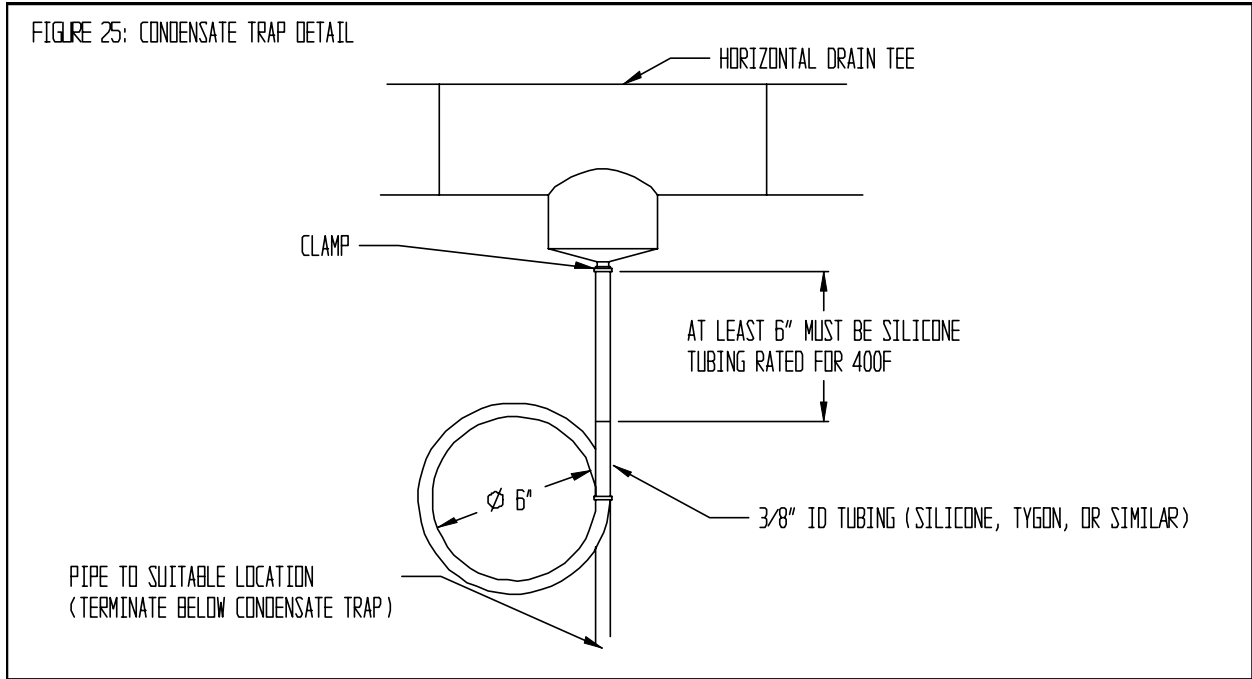

VII Gas Piping

Gas piping to the boiler must be sized to deliver adequate gas for the boiler to fire at the nameplate input at a line pressure between the minimum and maximum values shown on the rating plate. For more information on gas line sizing, consult the utility or Part 2 of the *National Fuel Gas Code*.

Figure 26 shows typical gas piping connections to the BWF boiler. A sediment trap must be installed upstream of all gas controls. Install a manual shutoff valve outside the jacket and ground joint union as shown.

The boiler and its gas connection must be leak tested before placing the boiler in operation. When doing this, the boiler and its individual shut-off must be disconnected from the rest of the system during any pressure testing of that system at pressures in excess of ½ psi. When pressure testing the gas system at pressures of ½ psi or less, isolate the boiler from the gas supply system by closing its individual manual shut-off valve.

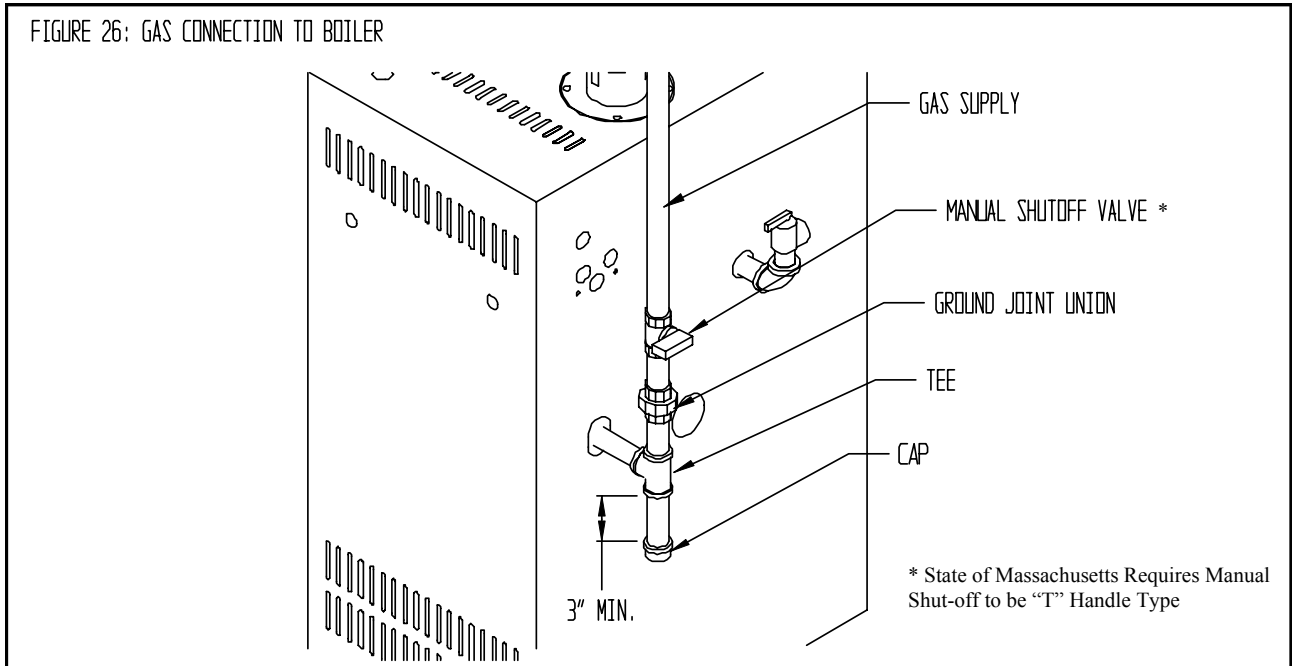

VIII System Piping

CAUTION

- INSTALL BOILER SO THAT THE GAS IGNITION SYSTEM COMPONENTS ARE PROTECTED FROM WATER (DRIPPING, SPRAYING, RAIN, ETC) DURING APPLIANCE OPERATION AND SERVICE (CIRCULATOR REPLACEMENT, ETC).
- OPERATION OF THIS BOILER WITH CONTINUOUS RETURN TEMPERATURES BELOW 120F CAN CAUSE SEVERE HEAT EXCHANGER CORROSION DAMAGE.
- OPERATION OF THIS BOILER IN A SYSTEM HAVING SIGNIFICANT AMOUNTS OF DISSOLVED OXYGEN CAN CAUSE SEVERE HEAT EXCHANGER CORROSION DAMAGE.
- DO NOT USE TOXIC ADDITIVES, SUCH AS AUTOMOTIVE ANTIFREEZE, IN A HYDRONIC SYSTEM.

Standard Piping

Figure 27 shows typical boiler system connections on a single zone system. Additional information on hydronic system design may be found in *Installation of Residential Hydronic Systems* (Pub. #200) published by the Hydronics Institute in Berkeley Heights, NJ. The components in this system and their purposes are as follows:

- 1) Relief valve (Required) – Mount the relief valve in the $\frac{3}{4}$ tapping on the right side of the boiler as shown in Figure 1 using the $\frac{3}{4}$ nipples and elbow provided. The relief valve shipped with the boiler is set to open at 30 psi. This valve may be replaced with one having a setting of up to the “Maximum Allowable Working Pressure” shown on the rating plate. If the valve is replaced, the replacement must have a relief capacity in excess of the DOE heating capacity for the boiler.

Pipe the discharge of the relief valve to a location where water or steam will not create a hazard or cause property damage if the valve opens. The end of the discharge pipe must terminate in an unthreaded pipe. If the relief valve discharge is not piped to a drain, it must terminate at least 6 inches above the floor. Do not run relief valve discharge piping through an area that could be subjected to freezing temperatures. The termination of the relief valve discharge piping must be in an area where it is not likely to become plugged by debris.

DANGER

- PIPE RELIEF VALVE DISCHARGE TO A SAFE LOCATION.
- DO NOT INSTALL A VALVE IN THE RELIEF VALVE DISCHARGE LINE.
- DO NOT INSTALL RELIEF VALVE IN ANY OTHER LOCATION THAN THAT SHOWN IN FIGURE 1.
- DO NOT PLUG RELIEF VALVE DISCHARGE.

- 2) Circulator (Required) – Although the circulator is shipped on the boiler return, it can be installed on the boiler supply. If the circulator is moved to the supply, it should be positioned just downstream of the expansion tank as shown in Figure 27.
- 3) Expansion Tank (Required) – If this boiler is replacing an existing boiler with no other changes in the system, the old expansion tank can generally be reused. If the expansion tank must be replaced, consult the expansion tank manufacturer’s literature for proper sizing.
- 4) Fill Valve (Required) – Either a manual or automatic fill valve may be used. The ideal location for the fill is at the expansion tank.
- 5) Automatic Air Vent (Required) – At least one automatic air vent is required. Manual vents will usually be required in other parts of the system to remove air during initial fill.
- 6) Low Water Cut-Off (Required in some situations) – A low water cut-off is required when the boiler is installed above radiation. In addition, some codes such as ASME CSD-1 require low water cut-offs. Codes may also require that this low water cut-off have a manual reset function. The low water cut-off may be a float type or probe type but must be designed for use in a hot-water system. The low water cut-off should be piped into the boiler supply just above the boiler with no intervening valve between it and the boiler.

Use a low water cut-off that breaks the 120 VAC supply to the boiler. Do not attempt to wire a 24- volt low water cut-off into the boiler factory wiring.

- 7) Manual Reset High Limit (Required by some codes) – This control is required by ASME CSD-1 and some other codes. Install the high limit in the boiler supply piping just beyond the boiler with no intervening valves. Set manual reset high limit as far above the operating limit setting as possible, but not over 240F. Wire the control to break the 120 VAC electrical supply to the boiler.
- 8) Flow control valve (Required under some conditions) – The flow control valve prevents flow through the system unless the circulator is operating. A flow control valve may be necessary on converted gravity systems to prevent gravity circulation. Flow control valves are also used to prevent “ghost flows” in circulator zone systems through zones that are not calling for heat.
- 9) Isolation Valves (Optional) – Isolation valves are useful if the boiler must be drained, as they will eliminate having to drain and refill the entire system.
- 10) Drain Valve – The drain valve is shipped in the boiler parts bag. Install it in the 3/4” opening in the tee on the boiler return (Figure 1).

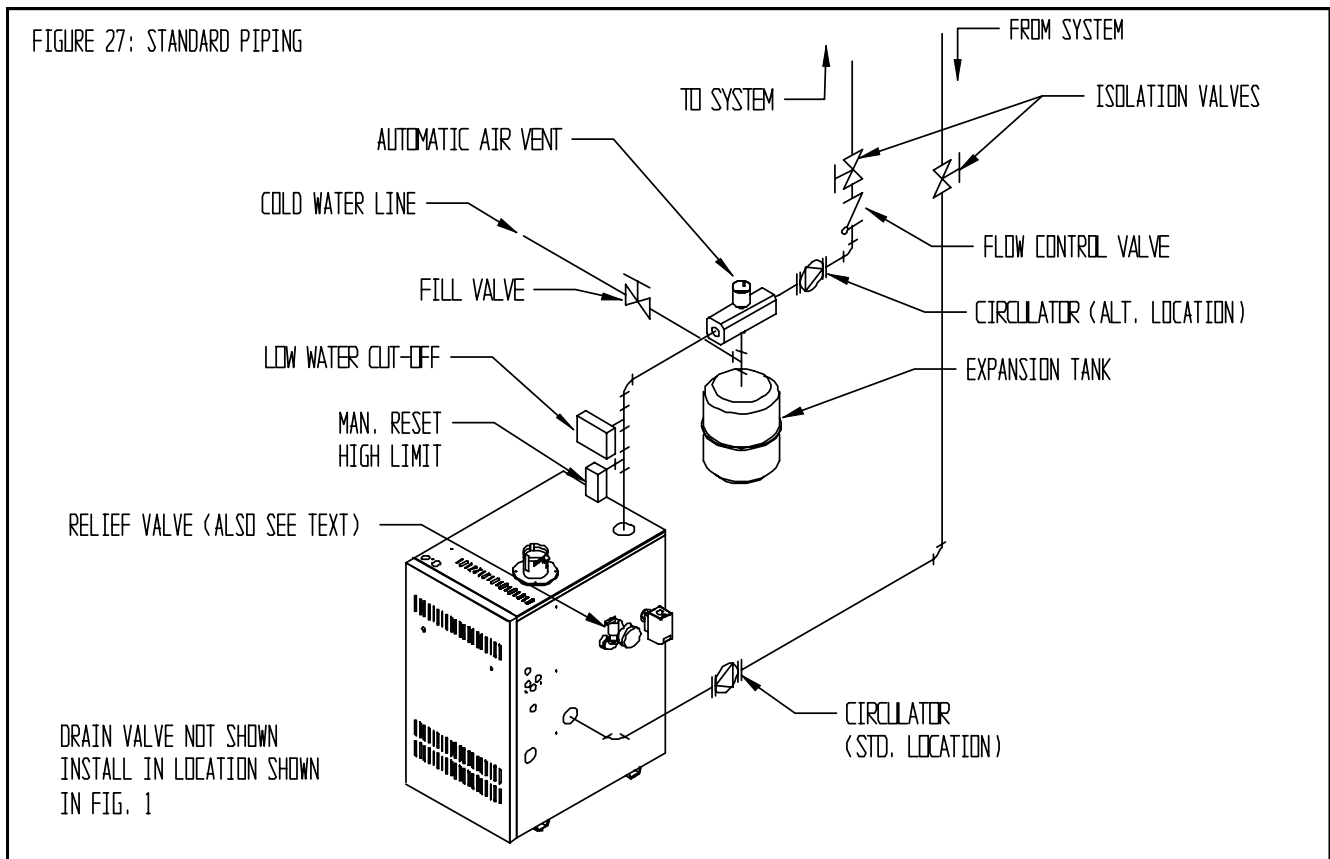

Piping for Special Situations

Certain types of heating systems have additional requirements. Some of the more common variations follow:

- 1) Indirect Water Heaters – Figure 28 shows typical indirect water heater piping. Boiler piping is the same as for any two-zone system. Figure 28 shows circulator zoning, which is usually preferred for indirect water heaters. Size the circulator and indirect water heater piping to obtain the boiler water flow through the indirect water heater called for by the indirect water heater manufacturer.

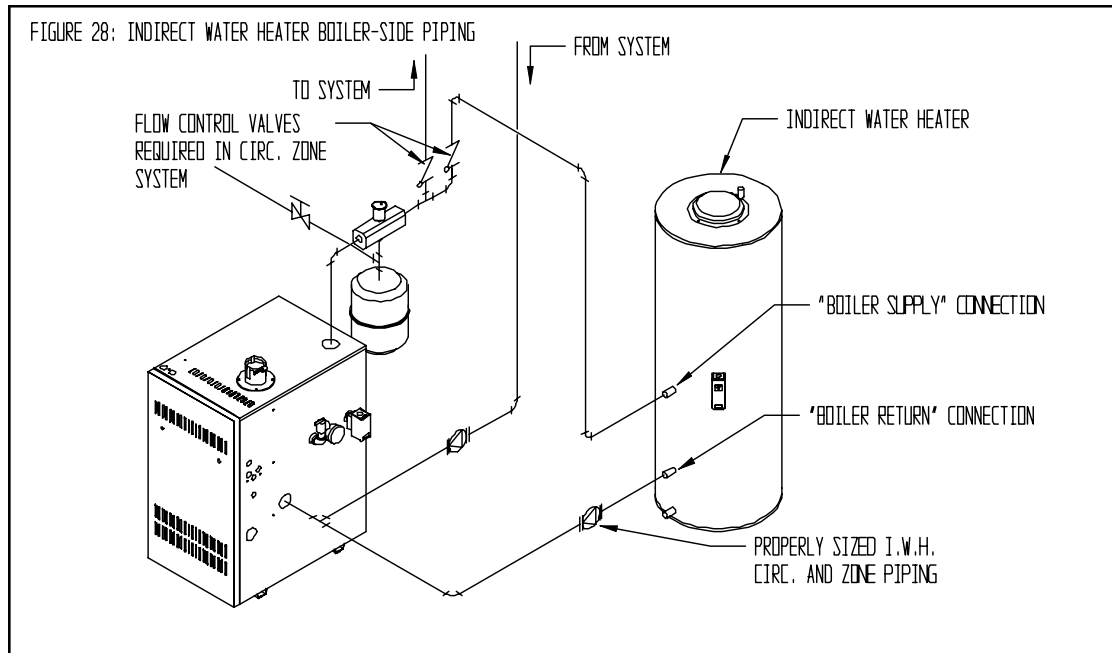

2) Gravity and “Large Water Volume” Systems – The piping shown in Figure 29 will minimize the amount of time that the boiler operates with return temperatures below 120F on these systems. A bypass is installed as shown to divert some supply water directly into the return water. The bypass pipe should be the same size as the supply. The two throttling valves shown are adjusted so that the return temperature rises above 120F during the first few minutes of operation. A three-way valve can be substituted for the two throttling valves shown. If the circulator is mounted on the supply, the bypass must be on the discharge side of the circulator.

3) Low Temperature Systems – Some systems, such as radiant tubing systems, require the system water temperature to be limited to a value below the temperature of the water leaving the boiler. These systems also typically have return temperatures well below the 120F minimum.

Figure 30 illustrates the use of a heat exchanger to connect a BWF boiler to this type of system. The heat exchanger will permit the transfer of heat from the boiler water to the low temperature system while holding the system supply and boiler return temperatures within their limits. For this system to work properly, the heat exchanger must be properly sized and the correct flow rates are required on either side of the heat exchanger. Consult the heat exchanger manufacturer for sizing information. The water in the boiler is completely isolated from the water in the system. This means that separate fill and expansion tanks are required for the heating system loop.

There are several other ways to connect low temperature systems to the non-condensing boilers like the BWF such as four way mixing valve and variable speed injection pumping systems.

4) Systems containing oxygen – Many hydronic systems contain enough dissolved oxygen to cause severe corrosion damage to a cast iron boiler such as the BWF. Some examples include:

- Radiant systems that employ tubing without an oxygen barrier.
- Systems with routine additions of fresh water.
- Systems which are open to the atmosphere.

If the boiler is to be used in such a system, it must be separated from the oxygenated water being heated with a heat exchanger as shown in Figure 30.

Consult the heat exchanger manufacturer for proper heat exchanger sizing as well as flow and temperature requirements. All components on the oxygenated side of the heat exchanger, such as the pump and expansion tank, must be designed for use in oxygenated water.

5) Piping with a Chiller – If the boiler is used in conjunction with a chiller, pipe the boiler and chiller in parallel as shown in Figure 31. Use isolation valves to prevent chilled water from entering the boiler.

- 6) Air Handlers – Where the boiler is connected to air handlers through which refrigerated air passes, use flow control valves in the boiler piping or other automatic means to prevent gravity circulation during the cooling cycle.

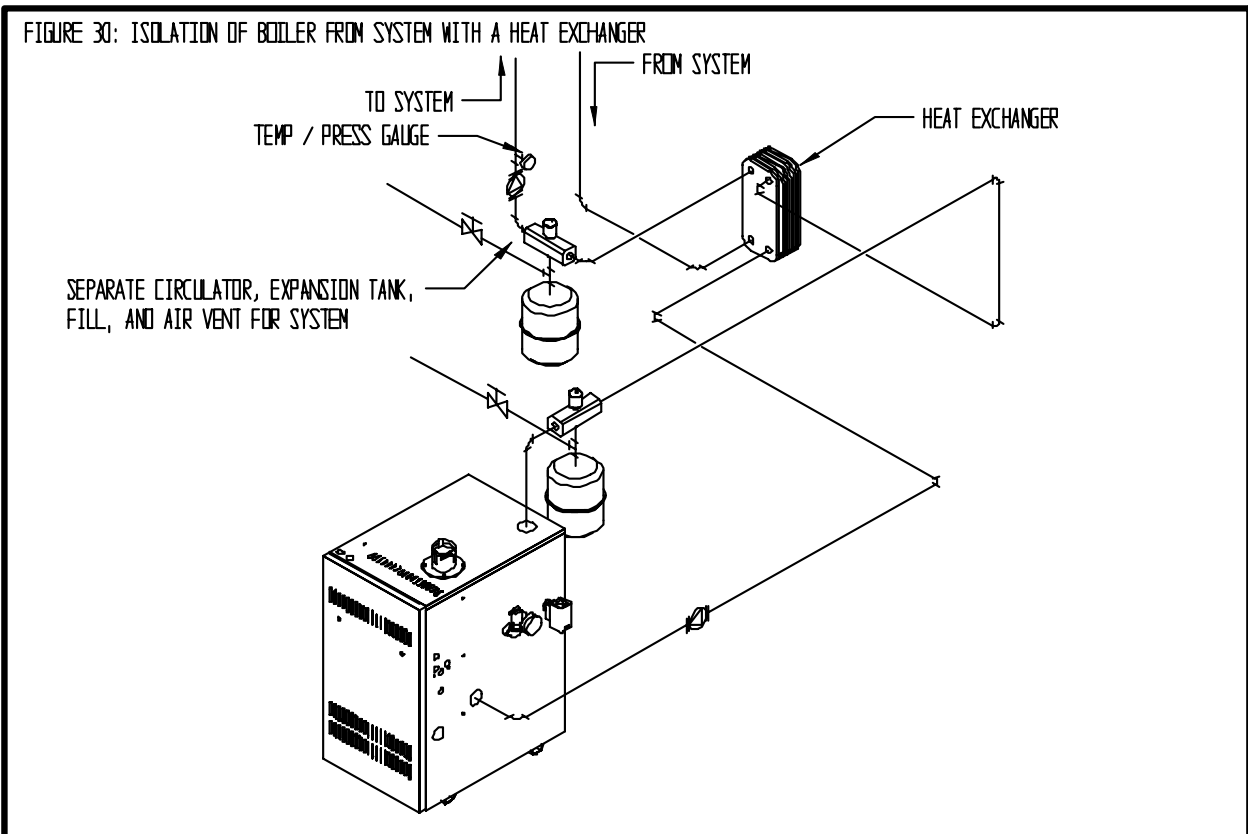
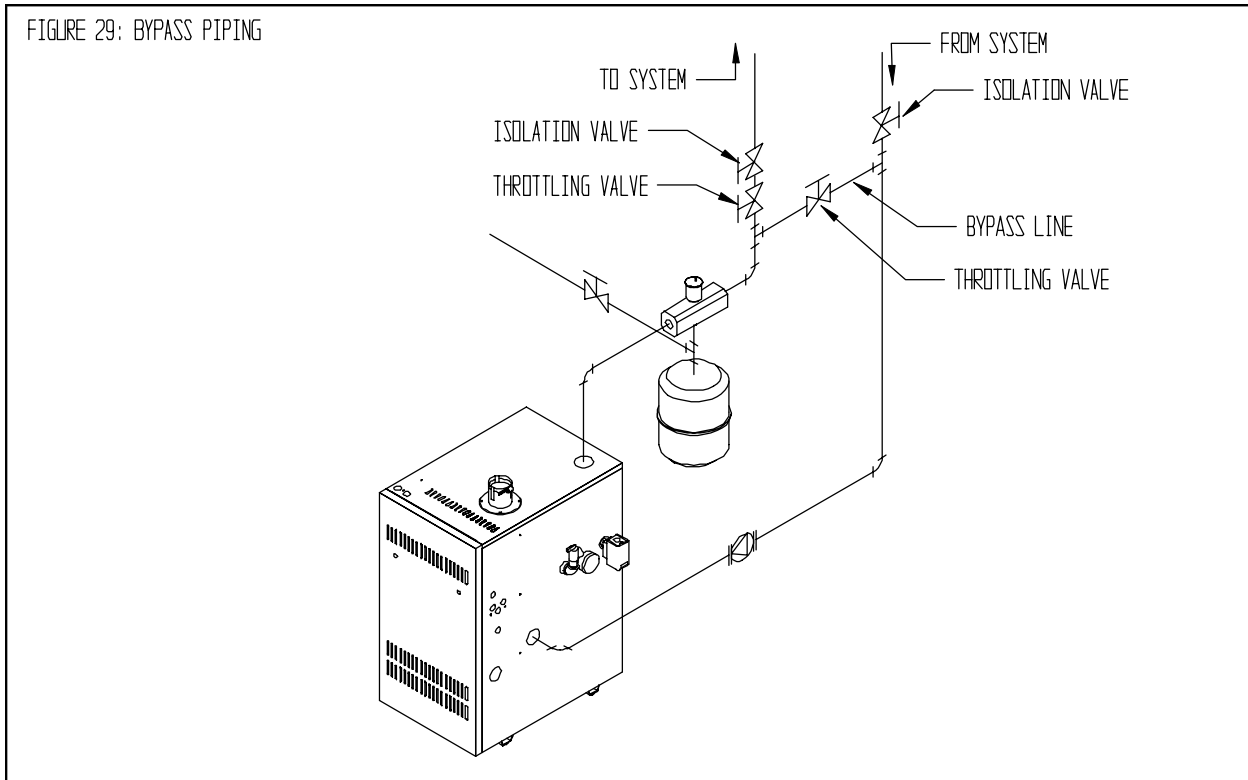
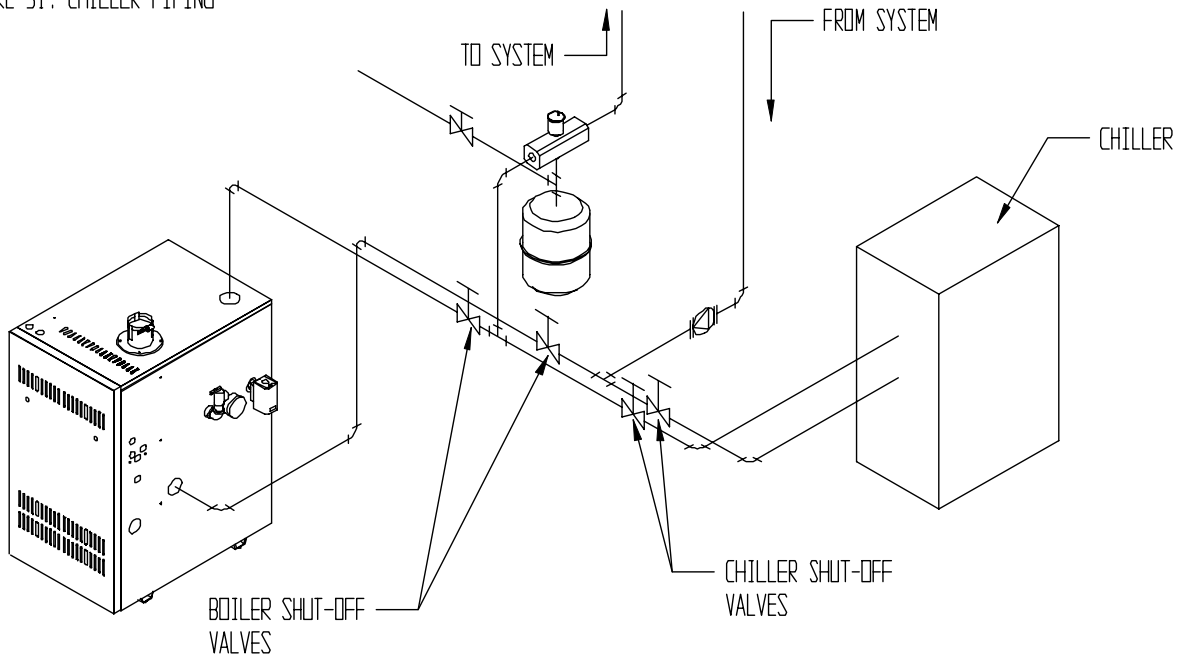

FIGURE 31: CHILLER PIPING



IX Wiring

WARNING

All wiring and grounding must be done in accordance with the authority having jurisdiction or, in the absence of such requirements, with the *National Electrical Code (ANSI/NFPA 70)*.

Single Zone Wiring

- 1) Line Voltage (120 VAC) Connections (Fig 32) – The line voltage connections are located in the junction box under the R8285 fan center on the right side of the boiler.
 - Black – Line voltage “hot”
 - White – “Neutral” for boiler and circulators
 - Green – Ground connection
- 2) The circulator is factory wired. If a different circulator is wired to the boiler, its full load current draw must not exceed 12A.
- 3) Connect the 24-volt thermostat to terminals “R” and “G” on the R8285 fan center. Set the heat anticipator to 0.34 Amps.

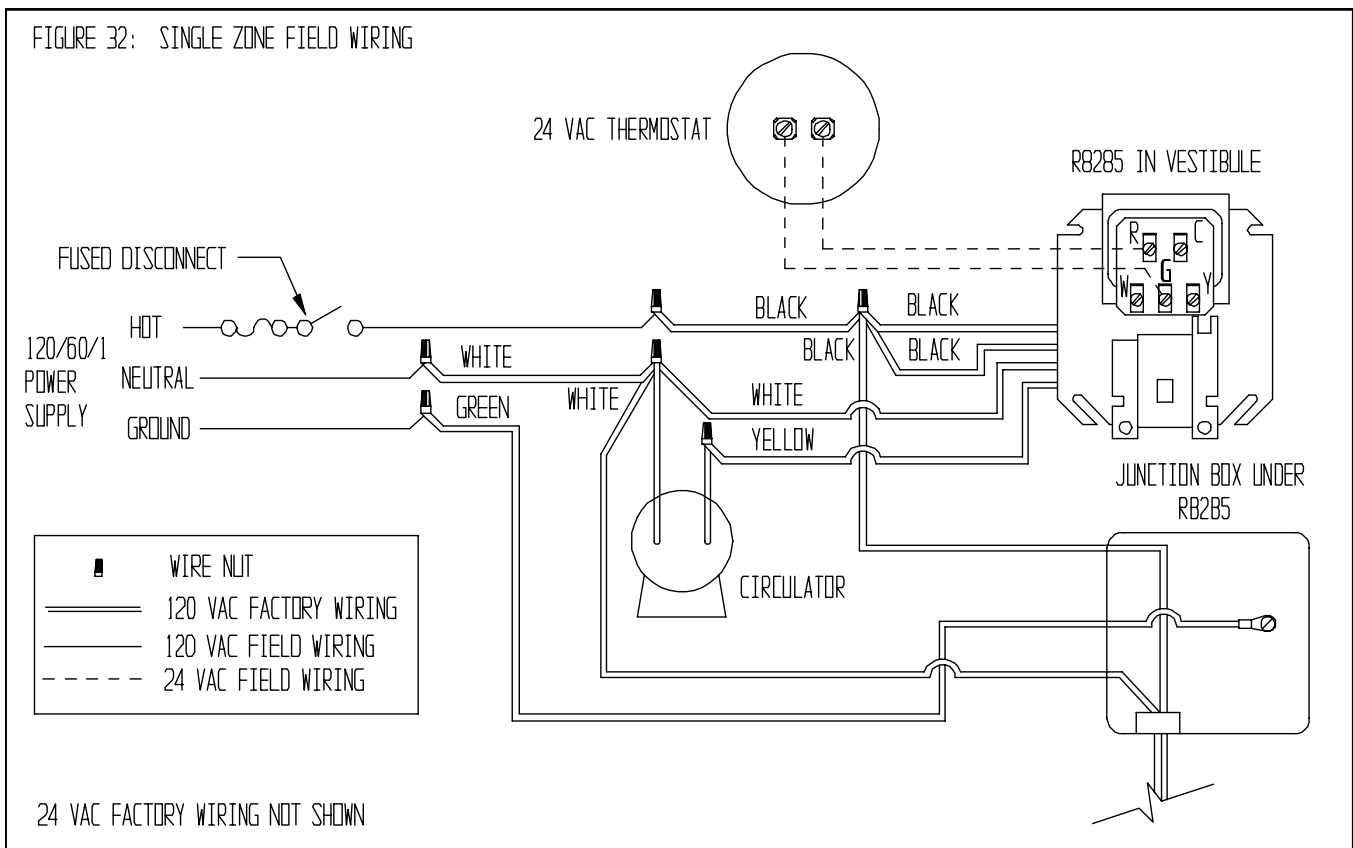

Wiring Variations

- 1) Multiple Circulator Zones – Figure 33 shows wiring for two or more circulator zones using Honeywell R845As. One fewer R845A is used than the total number of circulator zones. A DPST Honeywell RA832A may be substituted in place of the R845A using the “X” and “X” terminals in place of the “5” and “6” terminals on a R845A.

A call for heat from the “zone #1” thermostat causes the zone #1 circulator to start and the boiler to fire exactly as in a single zone system (see “Sequence of Operation”). A call for heat from any other thermostat will energize the DPST relay in that zone’s R845A. When this relay is energized, electrical continuity is created between terminals 3 and 4, energizing the circulator for that zone. At the same time, electrical continuity is created between terminals 5 and 6 on the R845A, creating a current path from terminal “R” to “Y” on the R8285 fan center in the BWF. Assuming that the supply water temperature is below the high limit setting, the normal ignition sequence will be initiated. If this happens when there is no call from the zone #1 thermostat, the relay on the R8285A will not be energized and the zone #1 circulator will remain off.

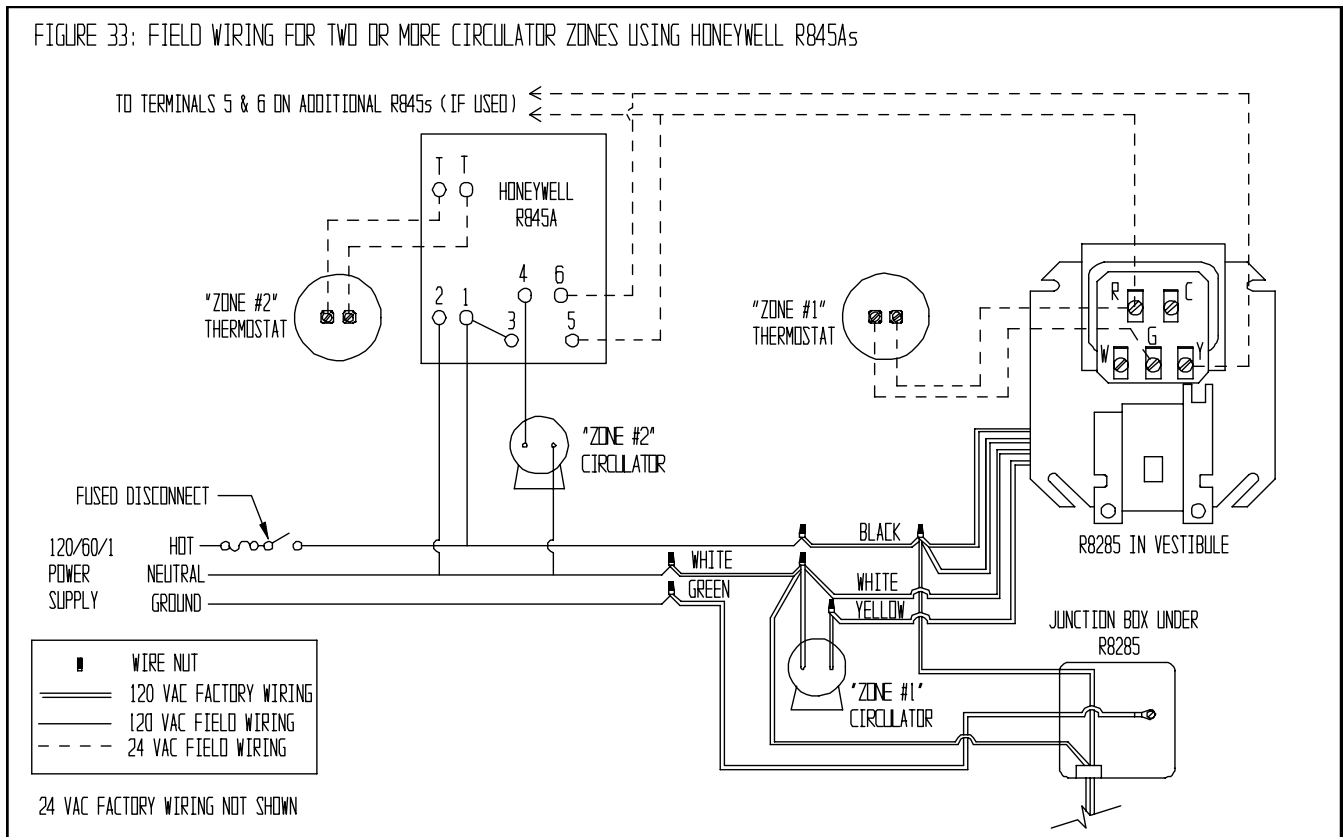

- 2) Multiple Zones using Zone Valves – Figure 34 shows wiring for multiple zones using Honeywell V8043F zone valves. This wiring diagram may be used for other 24-volt zone valves as long as they are equipped with end switches. **Do not attempt to use the transformer on the R8285 to power the zone valves;** use a separate transformer. Up to five V8043Fs may be powered by one 48VA transformer, such as the Honeywell AT87A.

A call for heat from a given thermostat will result in the application of 24 volts across the TH and TR terminals on the corresponding zone valve, energizing the zone valve motor. The zone valve opens and the end switch contacts are then made. The end switches are connected in parallel with each other and to the BWF “thermostat” connections so that any zone valve that opens will also start the circulator and fire the boiler (assuming the high limit is not open). Zone valve terminal TH/TR has no internal connection on the zone valve; it is merely a “binding post” used to connect two or more wires.

FIGURE 34: FIELD WIRING FOR TWO OR MORE ZONES USING HONEYWELL VBD43 ZONE VALVES

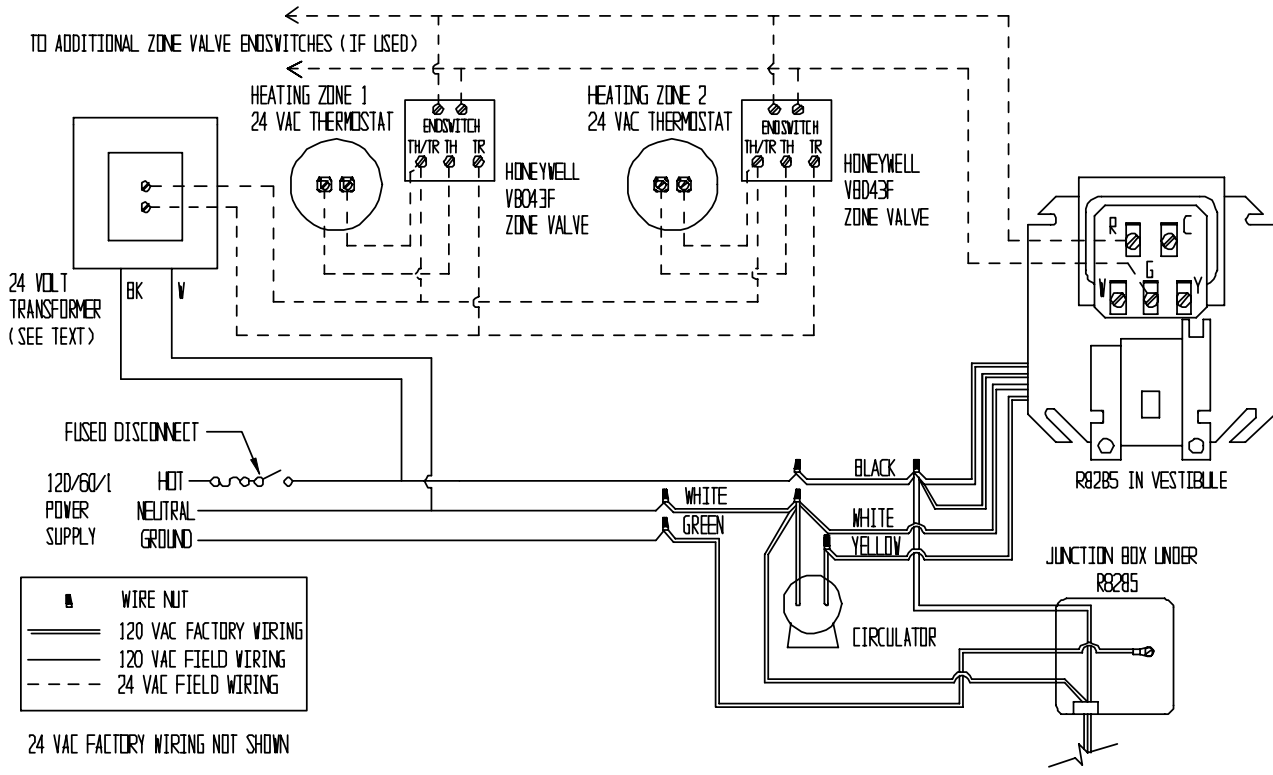
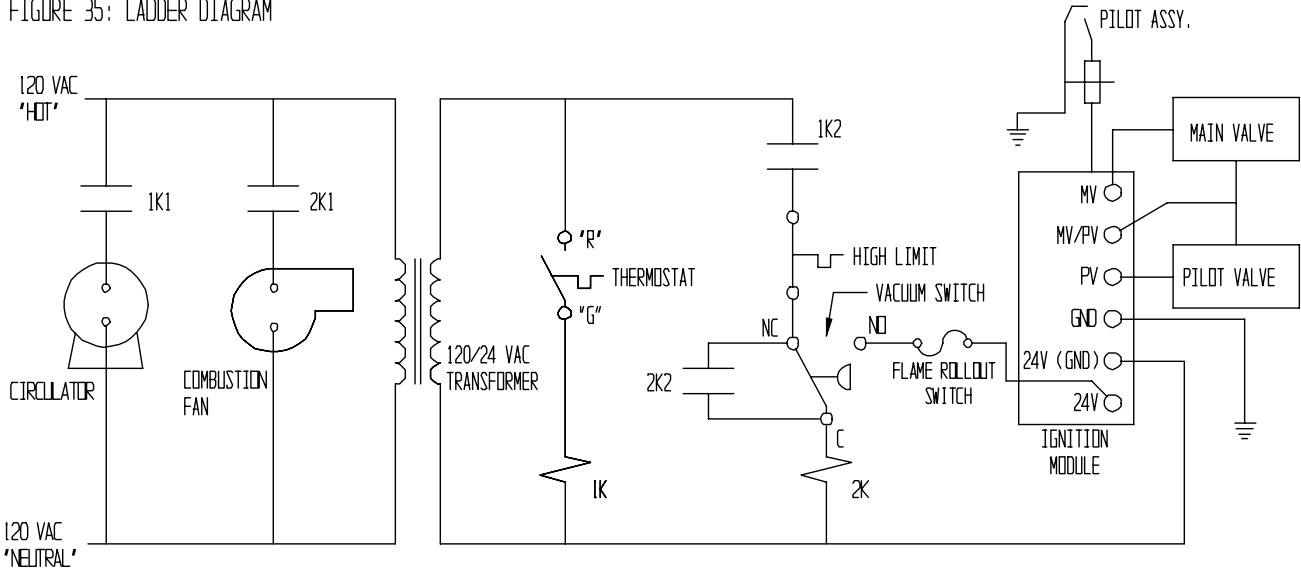

FIGURE 35: LADDER DIAGRAM



NOTES:

- 1) RELAY 1K: RELAY ON R8285 FAN CENTER
- 2) RELAY 2K: R8222D RELAY
- 3) CONTACT POSITIONS ARE SHOWN WITH NO CALL FOR HEAT AND WITH THE WATER TEMPERATURE BELOW THE HIGH LIMIT SETTING

BWF Control System – Sequence of Operation

(Refer to Figures 35 and 36 for BWF ladder and connection diagrams)

- 1) A call for heat from the thermostat energizes relay coil 1K (the relay on the R8285), causing contacts 1K1 and 1K2 to make. Contact 1K1 starts the circulator. Contact 1K2 sends power to the high limit.
- 2) Assuming that the high limit is made, current will flow through the normally closed contacts on the pressure switch to relay coil “2K” (the R8222 relay coil). Contacts 2K1 make, starting the combustion blower. Contacts 2K2 make, creating a current path in parallel with the normally closed pressure switch contacts.
- 3) As the combustion fan comes up to full speed, the normally closed contacts on the vacuum switch break. Power remains applied to the 2K coil, however, through the 2K2 contacts. Once the combustion fan has created an adequate vacuum at the vacuum switch tapping, the normally open contacts on the pressure switch will make, sending power to the ignition module via the normally closed flame rollout switch.
- 4) Upon application of voltage across the “24V” and “24V (GND)” terminals, the ignition module will enter a 30-second pre-purge period. After 30 seconds has passed, the module will start an ignition spark at the pilot and apply 24 volts across the pilot valve (terminals “PV” and “MV/PV”)
- 5) Once the pilot is established, the pilot flame will act as a diode, converting the AC current at the electrode to a half wave DC current at the pilot’s ground strap. This DC current flows through the boiler to the “GND (BURNER)” connection on the ignition module. For the ignition module to recognize that a pilot flame is present, the DC current flowing into this terminal must be in excess of approximately 1.0 uA.
- 6) Once the ignition module detects the presence of a pilot flame, voltage is applied across the main valve (terminals “MV” and “MV/PV”), opening the valve and establishing main flame.
- 7) If the ignition module does not detect the presence of a pilot flame after 90 seconds, the ignition spark will stop, the pilot valve will close, and the ignition module will wait for approximately 5 minutes before restarting the ignition sequence. During this time both the circulator and combustion fan will continue to run. If the pilot is never established, the ignition sequence will continue to be restarted at 5-minute intervals.
- 8) Assuming that main flame is established, the boiler will fire until either the call for heat is satisfied or until the water temperature exceeds the high limit setting. If the high limit setting is exceeded, relay coil 2K will be de-energized, turning off the burners and combustion fan. The circulator will continue to run until the call for heat is satisfied, regardless of the water temperature.
- 9) At the end of a burner cycle, the normally closed contacts on the vacuum switch should make after the fan is de-energized. If this does not happen, there will be no current path to relay coil 2K upon the next call for heat and the boiler will not fire.
- 10) The flame rollout switch is a normally closed thermal switch that is positioned at the burner compartment opening. In the event that flames exit this opening, the flame rollout switch will open, de-energizing the ignition module and closing the gas valve. Once opened, this switch must be replaced.

FIGURE 36: CONNECTIONS DIAGRAM

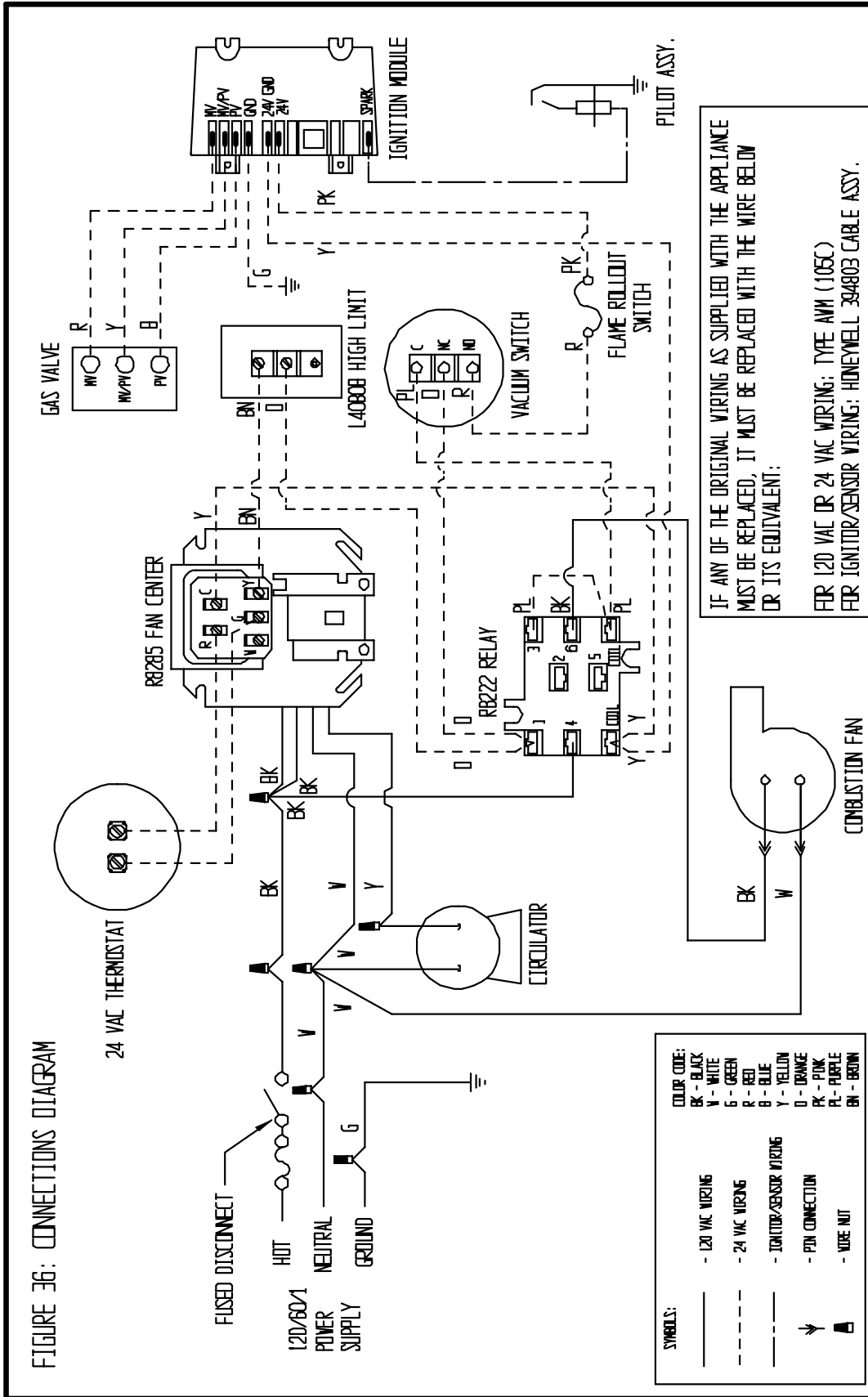

SYMBOLS:	
—	- 120 VAC WIRING
- - -	- 24 VAC WIRING
---	- IGNITOR/SENSOR WIRING
⚡	- FPN CONNECTION
⚡	- WIRE NUT

COLOR CODE:	
BK	- BLACK
W	- WHITE
G	- GREEN
R	- RED
B	- BLUE
Y	- YELLOW
D	- DRANGE
PK	- PINK
PL	- PURPLE
BN	- BROWN

IF ANY OF THE ORIGINAL WIRING AS SUPPLIED WITH THE APPLIANCE MUST BE REPLACED, IT MUST BE REPLACED WITH THE WIRE BELOW OR ITS EQUIVALENT:

FOR 120 VAC OR 24 VAC WIRING: TYPE ANW (105C)
 FOR IGNITOR/SENSOR WIRING: HONEYWELL 394803 CABLE ASSY.

IX Start-up and Checkout

NOTE

SAFE LIGHTING AND OTHER PERFORMANCE CRITERIA WERE MET WITH THE GAS MANIFOLD AND CONTROL ASSEMBLY PROVIDED ON THE BOILER WHEN THE BOILER UNDERWENT THE TESTS SPECIFIED IN Z21.13

Use the following procedure for initial start-up of the boiler:

- 1) Make sure that the boiler and system are filled with water.

WARNING

- IF ANTIFREEZE IS USED IN THE SYSTEM, IT MUST BE A NONTOXIC TYPE SUCH AS PROPYLENE GLYCOL.
- NEVER ATTEMPT TO FILL A HOT EMPTY BOILER.

- 2) Check all new piping for leaks and purge piping sections that are filled with air. See Part 4 of the *National Fuel Gas Code* for additional information on testing and purging gas lines.

WARNING

- NEVER USE A FLAME TO CHECK FOR GAS LEAKS.
- MAKE SURE THAT THE AREA AROUND THE BOILER IS CLEAR AND FREE FROM COMBUSTIBLE MATERIALS, GASOLINE, AND OTHER FLAMMABLE VAPORS AND LIQUIDS.

- 3) Vent system must be complete and free of obstructions before attempting to fire boiler. Make sure that the silicone cure time called for in the vent assembly instructions has passed before firing boiler.
- 4) Inspect all line voltage wiring for loose or uninsulated connections.
- 5) Start the boiler using the lighting instructions on page 36.

NOTE

The combustion chamber insulation panels in this boiler contain a cornstarch based binder which may emit a strong odor as it is burned out of the insulation when the boiler is fired for the first time. An hour or more of continuous firing may be required to burn off all of this binder. Open any windows and outside doors in the boiler room to maximize ventilation while this binder is burned out.

- 6) Inspect the pilot and main flames. These flames should be stable and mostly blue (Fig. 37, 38). No yellow tipping should be present; however, intermittent flecks of yellow and orange in the flames are normal.
- 7) Check the manifold pressure and adjust if necessary. To do this, use the following procedure.

WARNING

FAILURE TO FOLLOW THE FOLLOWING PROCEDURE EXACTLY COULD RESULT IN OVERFIRING OF THE BOILER AND A CARBON MONOXIDE HAZARD.

- a) Connect a manometer to the line pressure tap on the gas valve
- b) Check the line pressure with all gas appliances on and off. The line pressure at the boiler must be within the following limits regardless of what combination of appliances is firing:

Line Press (inches w.c.)	Natural Gas	LP Gas
Min.	5.0	11.0
Max.	14.0	13.0

FOR YOUR SAFETY READ BEFORE LIGHTING

WARNING: If you do not follow these instructions exactly, a fire or explosion may result causing property damage, personal injury or loss of life.

- A. This appliance is equipped with an ignition device which automatically lights the pilot. Do not try to light the pilot by hand.
- B. **BEFORE LIGHTING** smell all around the appliance area for gas. Be sure to smell next to the floor because some gas is heavier than air and will settle on the floor.
- WHAT TO DO IF YOU SMELL GAS**
- Do not try to light any appliance.
 - Do not touch any electric switch; do not use any phone in your building.
 - Immediately call your gas supplier from a neighbor's phone. Follow the gas supplier's instructions.
- If you cannot reach your gas supplier, call the fire department.
- C. Use only your hand to push in or turn the gas control knob. Never use tools. If the knob will not push in or turn by hand, don't try to repair it, call a qualified service technician. Force or attempted repair may result in a fire or explosion.
- D. Do not use this appliance if any part has been under water. Immediately call a qualified service technician to inspect the appliance and to replace any part of the control system and any gas control which has been under water.

OPERATING INSTRUCTIONS

1. **STOP!** Read the safety information above on this label.
2. Set the thermostat to lowest setting.
3. Turn off all electric power to the appliance.
4. This appliance is equipped with an ignition device which automatically lights the pilot. Do not try to light the pilot by hand.
5. Remove front access panel.
6. Rotate the gas control knob clockwise ↻ to **OFF**.
7. Wait five (5) minutes to clear out any gas. Then smell for gas, including near the floor. If you then smell gas, **STOP!** Follow "B" in the safety information above on this label. If you don't smell gas go to the next step.
8. Rotate the gas control knob counter clockwise ↶ to **"ON"**.
9. Replace front access panel.
10. Turn on all electric power to the appliance.
11. Set thermostat to desired setting.
12. If the appliance will not operate, follow the instructions "To Turn Off Gas To Appliance" and call your service technician or gas supplier.

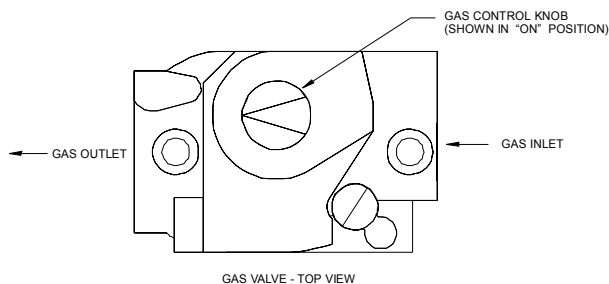

TO TURN OFF GAS TO APPLIANCE

1. Set the thermostat to lowest setting.
2. Turn off all electric power to the appliance if service is to be performed.
3. Push in gas control knob slightly and turn clockwise ↻ to **"OFF"**. Do not Force.

- c) If the line pressure falls outside of these limits, find and correct the cause of the problem before proceeding further.
- d) Connect a manometer to the manifold pressure tap on the gas valve (Fig. 41a).
- e) Read the manifold pressure. It should be set at:

Manifold Press. (inches w.c.)	Natural Gas	LP Gas
	3.5	10.0

- f) If a manifold pressure adjustment is needed, make the adjustment by turning the regulator screw clockwise to raise the pressure and counter clockwise to reduce the pressure (Fig 39).
 - g) If a manifold pressure adjustment is made, repeat steps (a)-(c) to be certain that the line pressure is still within acceptable limits.
 - h) Replace the cover screw on the regulator.
- 8) Perform a test of the flame supervision system. While the boiler is firing, disconnect the red ignition cable from the “Spark” terminal on the ignition module. Both the main and pilot flames should extinguish immediately.
 - 9) Allow the boiler temperature to increase to the high limit setting. Confirm that the high limit shuts down the burners and the combustion fan.
 - 10) Pinch or disconnect the vacuum switch tube that is connected to the fan. The burner should go out after a few seconds.
 - 11) Confirm that the thermostat(s) cycle the burner and appropriate circulators
 - 12) After the boiler has operated for approximately 30 minutes, check the boiler and heating system piping for leaks. Repair any leaks found at once.
 - 13) Inspect the vent system for flue gas leaks. Repair any leaks found before leaving the boiler in operation.

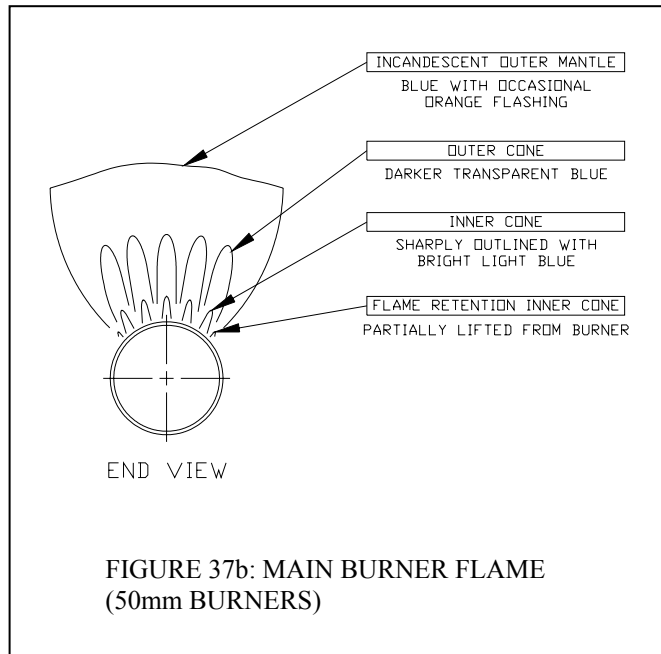
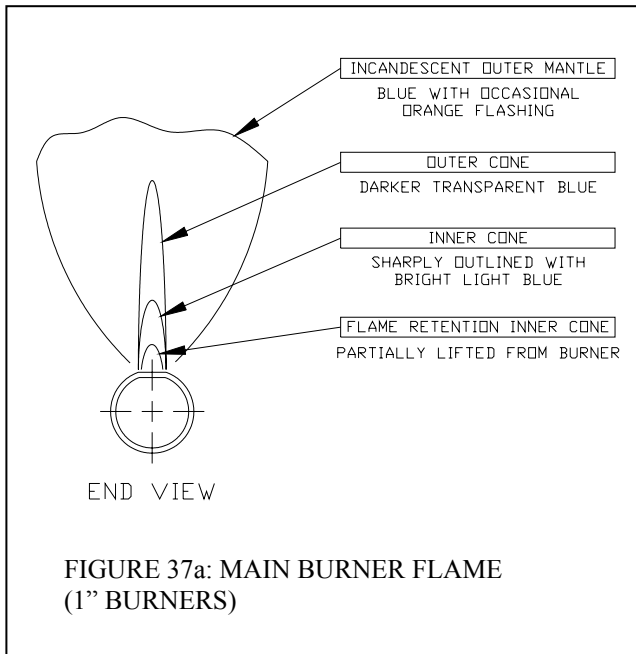

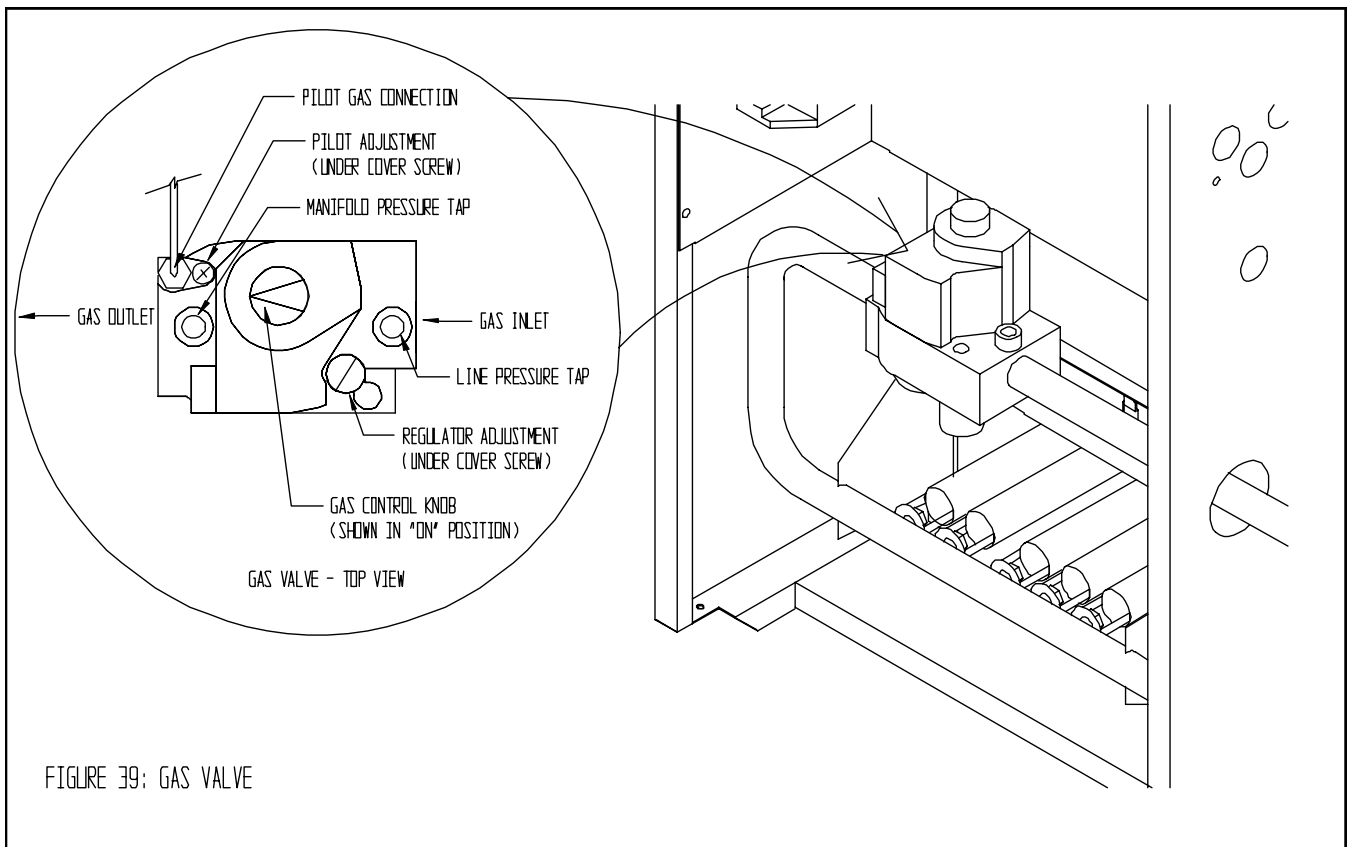
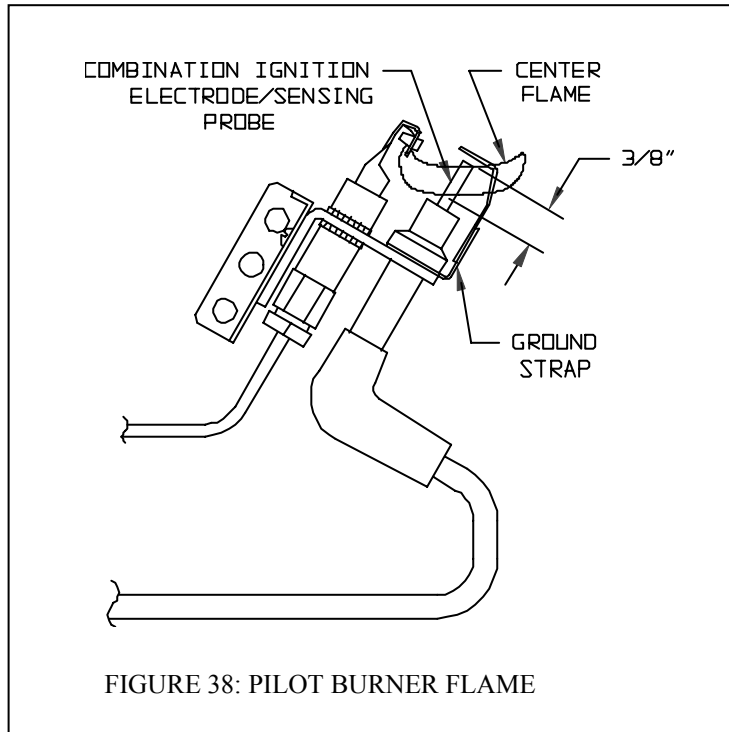

X Service and Maintenance

The following routine maintenance should be performed on an annual basis:

- 1) Turn off power to the boiler.
- 2) Inspect the flue passages for signs of blockage. If there is any carbon in the combustion chamber or the flue passages, clean the heat exchanger before proceeding further. See the cleaning procedure below.
- 3) Remove any debris found in the combustion chamber, being careful not to disturb combustion chamber insulation.
- 4) Remove all burners, noting the location of the pilot main burner. If burners show signs of deterioration, they should be replaced (some discoloration around the burner ports is normal). Clean the burners by first brushing the ports with a soft bristle brush and then vacuuming out any debris through the venturi opening.
- 5) Inspect the pilot assembly. Clean any deposits found on the electrode and grounding strap. The ideal gap between the electrode and the ground strap is 1/8". Inspect the porcelain for cracks or other deterioration. Replace pilot assembly if deterioration is found.
- 6) Inspect the combustion chamber insulation for deterioration.
- 7) Inspect the ignition cable insulation for cracks or other deterioration. If deterioration is found, replace cable.
- 8) Reinstall burners, being careful to put the pilot main burner in its original location.
- 9) Inspect all boiler wiring for loose connections or deterioration.

CAUTION

LABEL ALL WIRES PRIOR TO DISCONNECTION WHEN SERVICING CONTROLS. WIRING ERRORS CAN CAUSE IMPROPER AND DANGEROUS OPERATION. VERIFY PROPER OPERATION AFTER SERVICING.

- 10) Inspect the vacuum switch hose for deterioration. Clean out any condensate or other blockage found in this tube.
- 11) Disconnect the vent system from the boiler using the four 10-32 screws in the vent collar. Inspect the blower wheel and fan housing for corrosion damage. If damage is found, replace the fan assembly.
- 12) Inspect the vent system:
 - a) Make sure that the vent terminal is free of obstructions.
 - b) Make sure that all vent system supports are intact.
 - c) Inspect joints for signs of condensate or flue gas leakage.
 - d) If the vent system contains a condensate trap, make sure that the trap is in good condition and clear of blockages.
 - e) If this boiler is equipped with the optional Category I Vent Kit, refer to the vent kit instructions for additional maintenance information.

- 13) Inspect the boiler and hydronic system for leaks.

CAUTION

WATER LEAKS CAN CAUSE SEVERE CORROSION DAMAGE TO THE BOILER OR OTHER SYSTEM COMPONENTS. REPAIR ANY LEAKS FOUND IMMEDIATELY.

- 14) Place the boiler back in operation using the procedure outlined in "Start-up". Check the pilot line and any other gas piping disturbed during the inspection process for leaks.

Heat Exchanger Cleaning Procedure

- 1) Turn off power to the boiler.
- 2) Disconnect the vent system from the boiler by removing the four 10-32 screws holding the vent collar in place.
- 3) Remove the top jacket panel. If possible, remove the rear and left side jacket panels.
- 4) Unplug the fan and remove the fan cover plate.
- 5) Disconnect the pressure switch hose.
- 6) Remove the burners.
- 7) Remove the two 1/4-20 nuts and washers holding the flue collector onto the heat exchanger.
- 8) Score the silicone seal around the flue collector with a utility knife or similar tool.
- 9) Pry the flue collector off of the heat exchanger, being careful not to damage the flue collector or fan.
- 10) Clean the flue passageways using a stiff bristle brush. Be certain that all foreign material is removed from the gaps between the pins.

- 11) Clean the bottom surfaces of the heat exchanger.
- 12) Put a light in the combustion chamber and look through the flue passages from the top to verify that they have been thoroughly cleaned.
- 13) Apply a heavy (1/4") bead of RTV-732 silicone sealant with a 500F intermittent duty temperature rating around the perimeter of the heat exchanger.
- 14) Set the flue collector onto the block and press down so that the flue collector is set into the silicone applied in the previous step.
- 15) Replace the 1/4-20 nuts and washers that hold down the flue collector.
- 16) Apply a bead of silicone around the outside of the joint between the heat exchanger and the flue collector.
- 17) Reattach all the jacket components except for the fan cover plate.
- 18) Install the fan cover plate.
- 19) Plug in the fan and reconnect the vacuum switch tube.
- 20) Reconnect the vent system.

WARNING

SOOT DEPOSITS IN THE FLUE PASSAGES ARE A SIGN THAT THE BOILER MAY BE OPERATING AT HIGH CARBON MONOXIDE LEVELS. AFTER CLEANING THE BOILER OF SOOT DEPOSITS, CHECK BOTH CO AND CO2 LEVELS IN THE VENT BEFORE LEAVING THE BOILER IN OPERATION. CO AND CO2 READINGS SHOULD BE BELOW THE MAXIMUM LIMITS SHOWN IN TABLE 8.

Service Notes

- 1) Measuring CO and CO2 – If it is necessary to check CO or CO2, the best place to take a gas sample will usually be at the vent terminal. Table 8 shows typical and maximum readings for CO and CO2 on both natural and LP gas. Do not leave the boiler in operation if either the CO or CO2 exceeds the maximum limit in this table. Some causes of excessive CO or CO2 include:

- Incorrectly sized or drilled burner orifice
- Partially plugged flue passages
- Improper manifold pressure
- Partial blockage of vent system
- Foreign material in burner venturis or burner ports
- Distorted burner ports
- Distorted burner venturi bracket
- Damaged fan impeller or housing
- Damaged or missing fan gasket
- Leak in seal between flue collector and heat exchanger
- Inadequate supply of combustion air
- Damaged base

**TABLE 8: TYPICAL AND MAXIMUM
ACCEPTABLE CO2 AND CO READINGS IN FLUE
GAS**

	NATURAL GAS	LP GAS
TYPICAL CO2 (%)	7.5	8.5
MAXIMUM CO2 (%)	9.0	10.5
TYPICAL CO (PPM)	20	20
MAX. CO (PPM)	70	70

- 2) Orifice Size – Refer to the parts list in the back of this manual for sea level orifice sizes. Consult your Crown representative for correct orifice sizes for use at altitudes above 2000 ft. Orifice for this boiler cannot be drilled in the field.

- 3) Vacuum Switch – This boiler is equipped with a vacuum switch that is designed to prevent burner operation if the combustion fan does not operate properly or there is a blockage in the vent system. This switch “makes” (permits burner operation) as the vacuum increases. Figure 40 shows the correct method of reading the switch vacuum. The vacuums in Table 9 are the minimums required for reliable operation. After the boiler fires, the vacuum will drop for several minutes before stabilizing. The vacuum shown under “Burners On” in Table 9 is the minimum reading which should be observed after the vacuum has stabilized. The Table 9 readings correspond to sea level vacuum switch settings. Consult your Crown representative for possible variations in settings at altitudes over 2000ft.

TABLE 9: MINIMUM. VACUUM SWITCH READINGS (in. W.C.)

MODELS	DURING PREPURGE	BURNERS ON
BWF061, BWF095	-0.57	-0.51
BWF128, BWF162	-0.96	-0.89
BWF195, BWF229	-1.21	-1.14

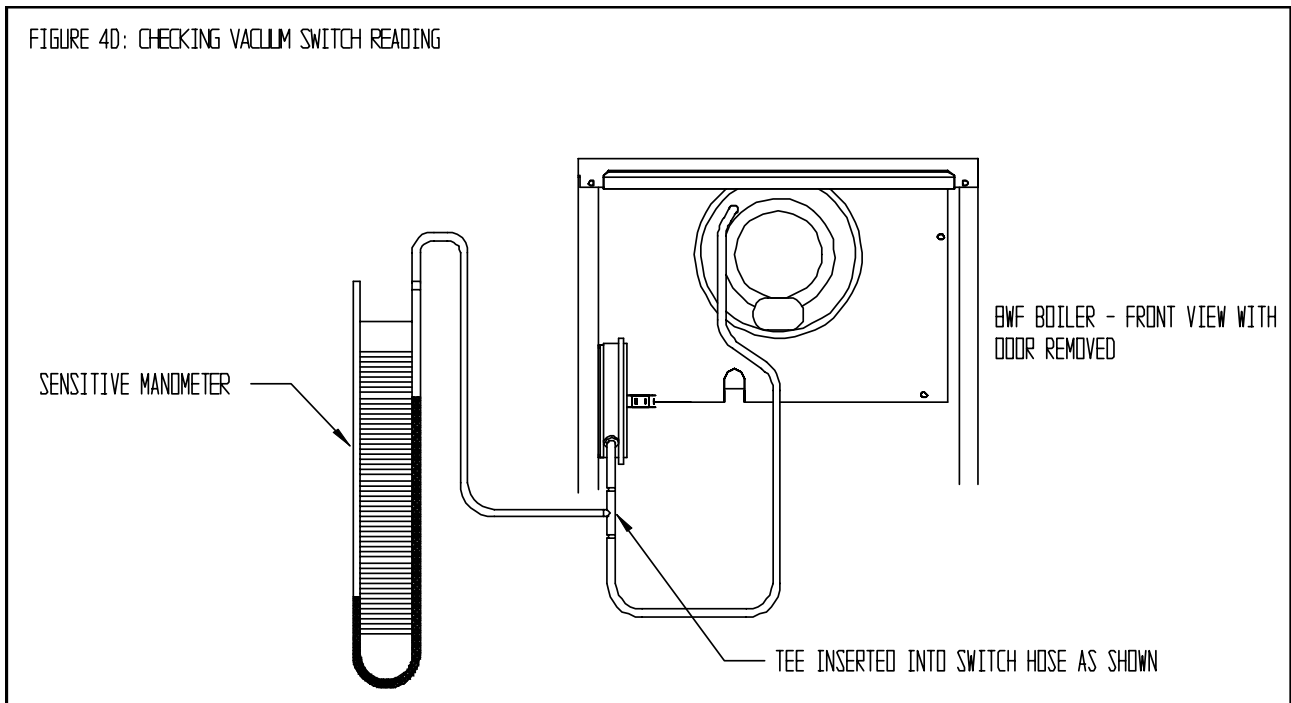

XII Troubleshooting

The following three pages contain troubleshooting charts for use in diagnosing control problems. To use these charts, go to the box marked “Start” at the top of the next page and follow the appropriate path through the chart until a box with a list of possible causes is reached. If the problem is known to be within the ignition system, go directly to the Intermittent Ignition Troubleshooting guide on page 46. In using these charts, the following should be kept in mind:

- 1) These charts are only meant to be used by a professional heating technician as an aid in diagnosing control problems.
- 2) Where applicable, follow all precautions outlined in the lighting instructions on page 37.
- 3) In general, these charts assume that there are no loose or miswired electrical connections. Before using these charts, inspect all electrical connections on the boiler to make sure that they are tight. Also, check the wiring on the boiler against the wiring diagram in Figure 36.
- 4) The possible causes at the end of each branch in these charts are not listed in order of likelihood. All controls on the BWF are tested at least once in the manufacturing process and a defective control or component is generally the least likely cause. Before replacing a component, try to rule out all other possible causes.
- 5) If the charts indicate that the transformer in the R8285 is defective, it is possible that this transformer has been destroyed by a short circuit in the boiler wiring. Before replacing the R8285, carefully inspect all low voltage wiring on the boiler for places where it is touching the frame of the boiler or wiring on the other side of the transformer.
- 6) If the charts indicate that the relay on the R8285 or the R8222 relay is defective, inspect the coil of the relay for visible heat damage. If such damage is found, there is a good chance that a second transformer is present in the thermostat or zone valve circuit, resulting in the application of 48 volts across the relay coil. In older buildings, this transformer may be hidden in a location far from the boiler. If this second transformer exists, it must be found and removed before the relay is replaced.

BWF Troubleshooting Chart

Caution: Read page 43 before attempting to use this chart

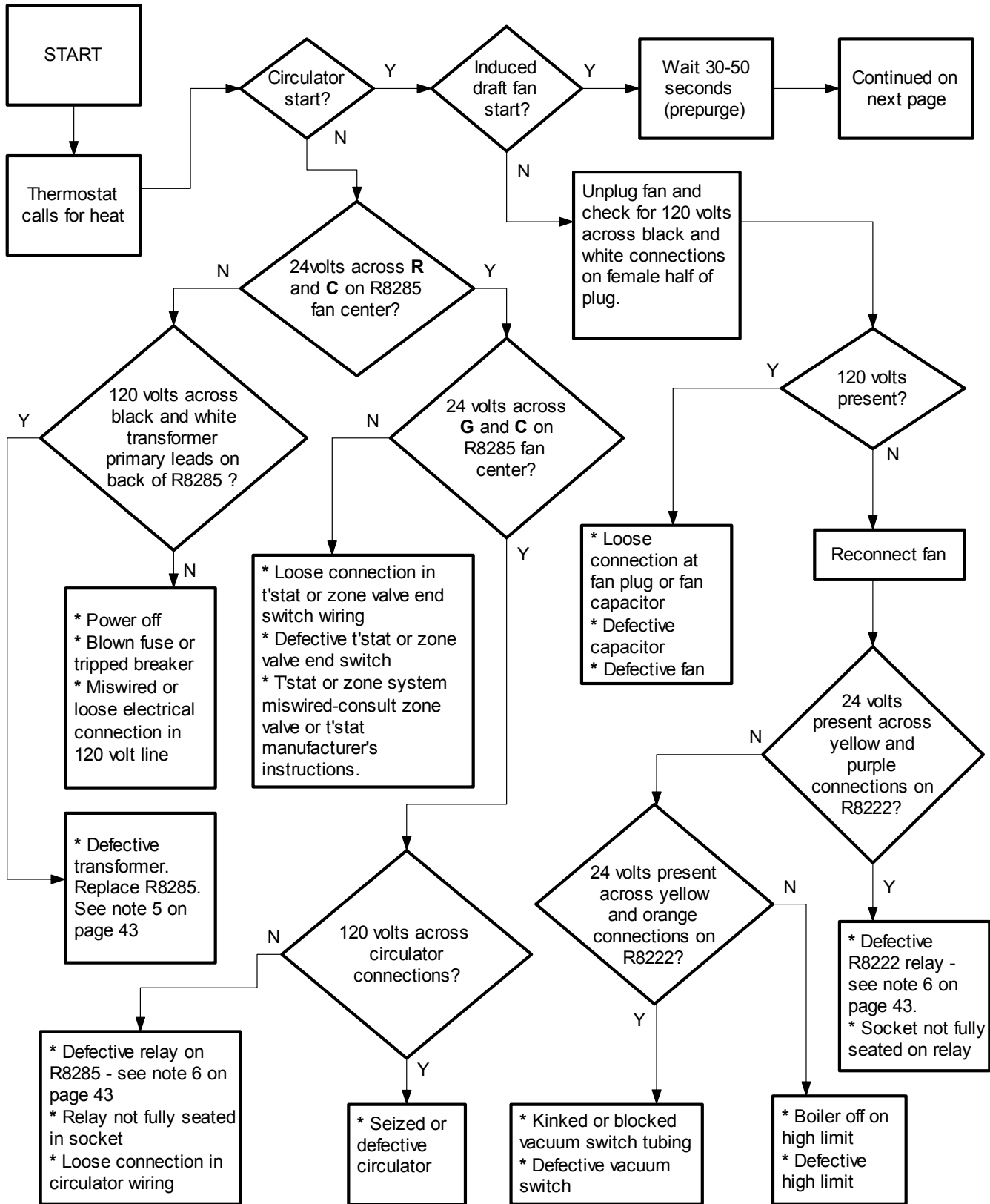

BWF Troubleshooting Chart (contd.)

Caution: Read page 43 before attempting to use this chart.

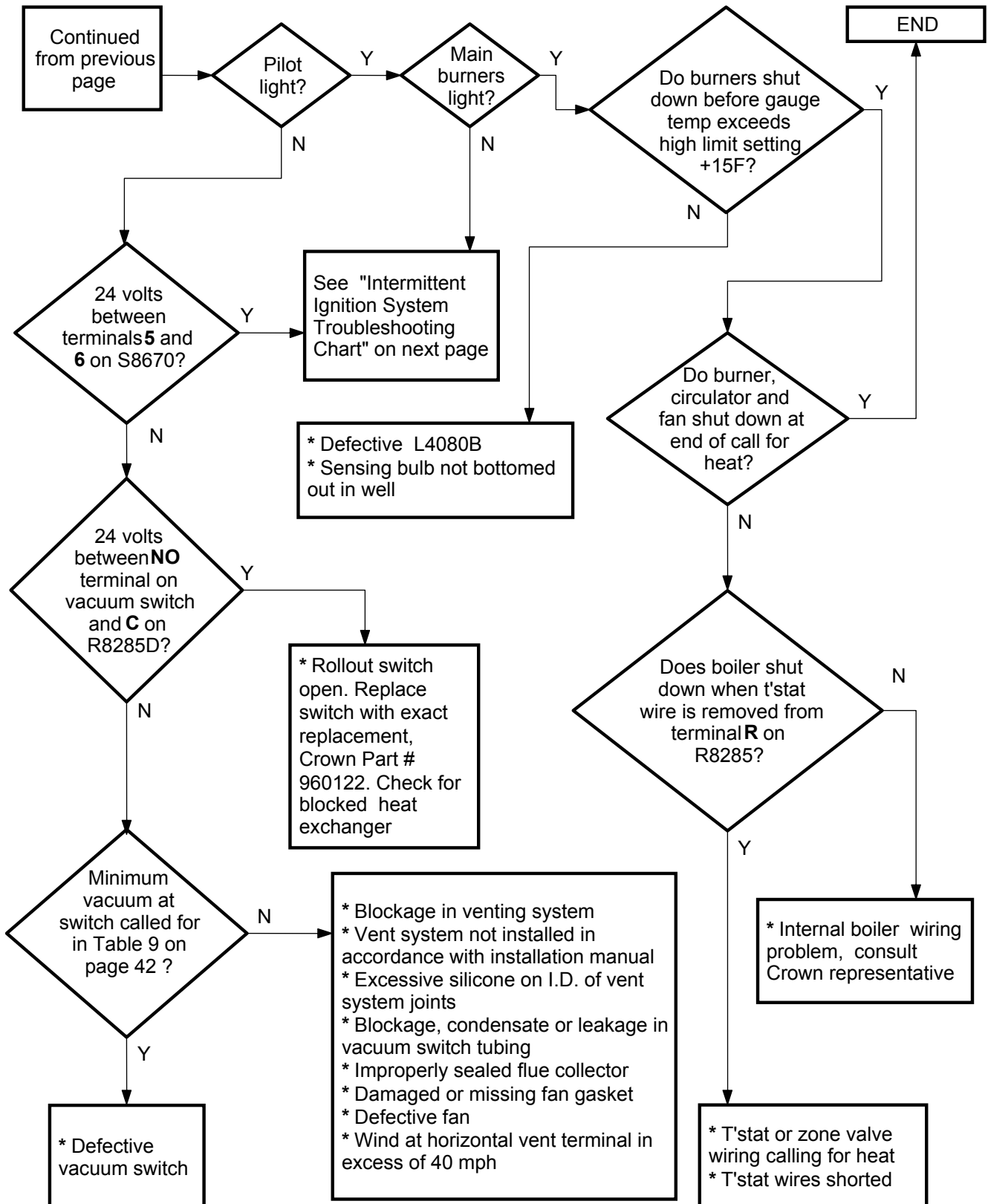

Intermittent Ignition System Troubleshooting Chart

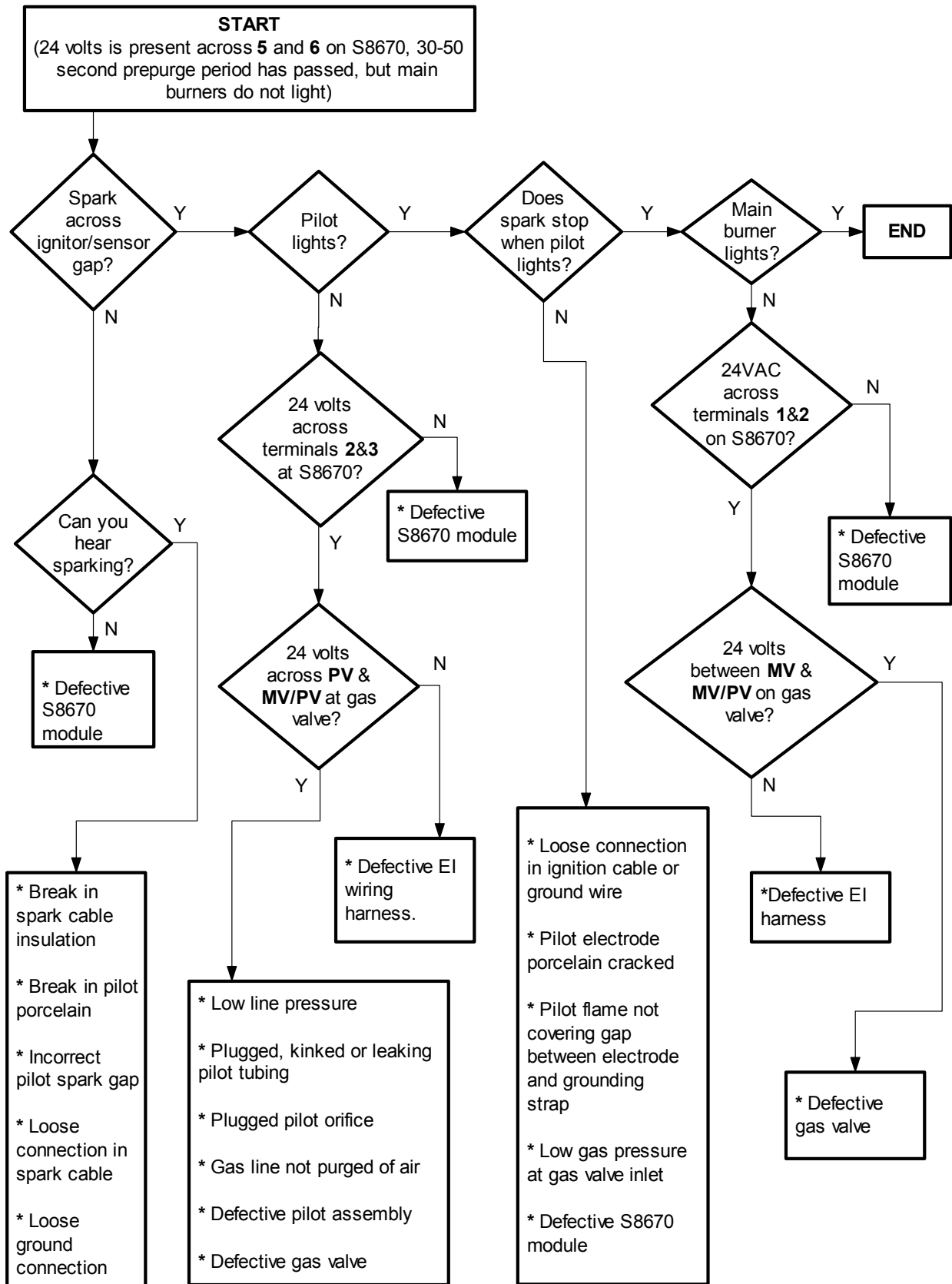

XI PARTS

The following parts may be obtained from any Crown distributor. To find the closest Crown distributor, consult the area Crown representative or the factory at:

Crown Boiler Co.
Customer Service
P.O. Box 14818
Philadelphia Pa. 19134
(215)-535-8900
www.crownboiler.com

Main burner orifice and vacuum switch part numbers shown are for sea level configured boilers. For boilers installed at elevations above 2000 ft, consult the local Crown representative or the factory for the correct main burner orifice and vacuum switch.

In some cases, the following parts lists do not include Crown part numbers because they were not available at the time of printing. Order these parts by their description, specifying the boiler model number on which they are to be used.

KEY #	DESCRIPTION	QTY. OR CROWN P.N.	QUANTITY PER BOILER OR CROWN P.N.					
			61	95	128	162	195	229
1	COMPLETE HEAT EXCHANGER ASSY.	1 ea.	700013	700014	700015	700016	700017	700018
*	LEFT END SECTION	700001	1 ea.	1 ea.	1 ea.	1 ea.	1 ea.	1 ea.
*	RIGHT END SECTION	700002	1 ea.	1 ea.	1 ea.	1 ea.	1 ea.	1 ea.
*	INTERMEDIATE SECTION	700003	1 ea.	2 ea.	3 ea.	4 ea.	5 ea.	6 ea.
*	PUSHNIIPLE	700000	4 ea.	6 ea.	8 ea.	10 ea.	12 ea.	14 ea.
2	BASE TRAY	1 ea.	700643	700644	700645	700646	700647	700648
3	BASE WRAPPER	1 ea.	700663	700664	700665	700666	700667	700668
4	BURNER TRAY (1" BURNERS)	1 ea.	700683	700684	700685	700686	700687	700688
4	BURNER TRAY (50mm BURNERS)	1 ea.	701683	701684	701685	701686	701687	701688
5	BASE FRONT PANEL ASSY. (INCLUDES INSULATION)	1 ea.	700603	700604	700605	700606	700607	700608
6	BURNER ACCESS PANEL	1 ea.	700623	700624	700625	700626	700627	700628
7	BASE END INSULATION	720601	2 ea.	2 ea.	2 ea.	2 ea.	2 ea.	2 ea.
8	BASE REAR INSULATION	1 ea.	720603	720604	720605	720606	720607	720608
9	BASE LEG ASSY.	700110	4 ea.	4 ea.	4 ea.	4 ea.	4 ea.	4 ea.
10	1/4-20 X 1/2" SELF TAPPING SCREW	900100	20 ea.	20 ea.	20 ea.	20 ea.	21 ea.	21 ea.
11	1/2" x 2" SEALING STRIP	900146	3.7 ft	4 ft	4.2 ft	4.5 ft	4.8 ft	5.1ft
12	ROLLOUT SWITCH G4AM0600240C	960122	1 ea.	1 ea.	1 ea.	1 ea.	1 ea.	1 ea.
13	ROLLOUT SWITCH BRACKET	900121	1 ea.	1 ea.	1 ea.	1 ea.	1 ea.	1 ea.
14	#8 x 3/4" SELF TAPPING SCREW	90-048	1 ea.	1 ea.	1 ea.	1 ea.	1 ea.	1 ea.
15	#10 x 1/2" SHEET METAL SCREW	90-212	1 ea.	1 ea.	1 ea.	1 ea.	1 ea.	1 ea.
16	5/16 USS FLAT WASHER	900102	4 ea.	4 ea.	4 ea.	4 ea.	4 ea.	4 ea.
17	5/16-18 LOCK NUT	900103	4 ea.	4 ea.	4 ea.	4 ea.	4 ea.	4 ea.
18	5/16-18 x 1-1/4 SELF TAPPING SCREW	900101	4 ea.	4 ea.	4 ea.	4 ea.	4 ea.	4 ea.
19	FLUE BAFFLE	650100	2 ea.	3 ea.	4 ea.	5 ea.	6 ea.	7 ea.
20	FLUE COLLECTOR ASSY.	1 ea.	651123	651124	651125	651126	651127	651128
21	FAN GASKET	650002	1 ea.	1 ea.	1 ea.	1 ea.	1 ea.	1 ea.
22	FAN ASSY.	60-001	1 ea.	1 ea.	1 ea.	1 ea.	1 ea.	1 ea.
22a	REPLACEMENT FAN CAPACITOR	60-003	1 ea.	1 ea.	1 ea.	1 ea.	1 ea.	1 ea.
23	FAN OUTLET ORIFICE	1 ea.	650133	650134	650135	650136	650137	650138
24	COLLAR GASKET	60-600	2 ea.	2 ea.	2 ea.	2 ea.	2 ea.	2 ea.
25	VENT COLLAR	1 ea.	60-603	60-603	60-603	60-603	60-604	60-604
26	#10 FLAT WASHER	90-057	4 ea.	4 ea.	4 ea.	4 ea.	4 ea.	4 ea.
27	10-32 X 1/2" R.H. SCREW	90-058	4 ea.	4 ea.	4 ea.	4 ea.	4 ea.	4 ea.
28	#10 x 3/4" SHEET METAL SCREW	90-054	4 ea.	4 ea.	4 ea.	4 ea.	4 ea.	4 ea.
29	1/4-20 x 1-1/4" CARRIAGE BOLT	90-201	2 ea.	2 ea.	2 ea.	2 ea.	2 ea.	2 ea.
30	1/4-20 NUT	90-202	2 ea.	2 ea.	2 ea.	2 ea.	2 ea.	2 ea.
31	1/4" USS FLAT WASHER	90-215	2 ea.	2 ea.	2 ea.	2 ea.	2 ea.	2 ea.
*	10.1 oz TUBE SILICONE SEALANT (FOR SEALING FLUE COLLECTOR)	90-045	1 ea.	1 ea.	1 ea.	1 ea.	1 ea.	1 ea.

* NOT PICTURED

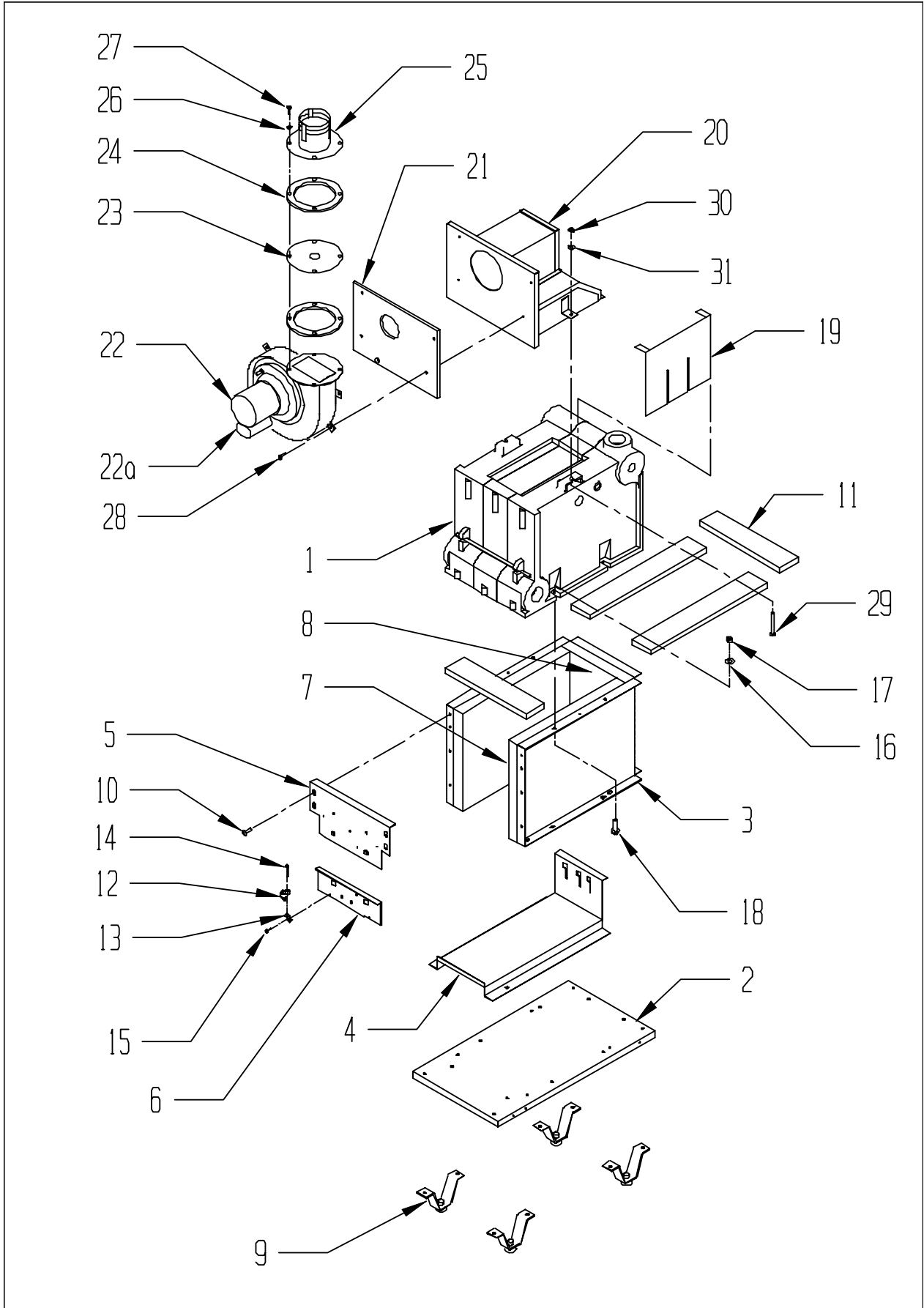

KEY #	DESCRIPTION	QTY. OR CROWN P.N.	QUANTITY PER BOILER OR CROWN P.N.					
			61	95	128	162	195	229
41	1" BURNER WITH PILOT BRACKET	150500	1 ea.	1 ea.	1 ea.	1 ea.	1 ea.	1 ea.
42	1" BURNER LESS PILOT BRACKET	150501	2 ea.	4 ea.	6 ea.	8 ea.	11 ea.	13 ea.
43	MANIFOLD (1" BURNERS)	1 ea.	650153	650154	650155	650156	650157	650158
44	NAT GAS ORIFICE (#44 DRILL SIZE)	950300	3 ea.					
44	NAT GAS ORIFICE (#45 DRILL SIZE)	950301		5 ea.				
44	NAT GAS ORIFICE (#46 DRILL SIZE)	950302			7 ea.	9 ea.		
44	NAT GAS ORIFICE (#48 DRILL SIZE)	950304					12 ea.	14 ea.
44	LP GAS ORIFICE (#55 DRILL SIZE)	950330	3 ea.					
44	LP GAS ORIFICE (1.25mm DRILL SIZE)	950336		5 ea.	7 ea.	9 ea.		
44	LP GAS ORIFICE (#56 DRILL SIZE)	950331					12 ea.	14 ea.
45	GAS VALVE (NAT GAS)	3507020 (VR8204C6000)	1 ea.	1 ea.	1 ea.	1 ea.		
45	GAS VALVE (NAT GAS)	3507120 (VR8304P4298)					1 ea.	1 ea.
45	GAS VALVE (LP GAS)	3507220 (VR8204C6018)	1 ea.	1 ea.	1 ea.	1 ea.		
45	GAS VALVE (LP GAS)	3507245 (VR8304P3522)					1 ea.	1 ea.
46	PILOT ASSY. (NAT GAS)	35-4700 (Q348A1275)	1 ea.	1 ea.	1 ea.	1 ea.	1 ea.	1 ea.
46	PILOT ASSY. (LP GAS)	35-4600 (Q348A1259)	1 ea.	1 ea.	1 ea.	1 ea.	1 ea.	1 ea.
47	IGNITION CABLE	1 ea.	3501124	3501124	3501124	3501130	3501130	3501130
48	PILOT TUBING	1 ea.	90-042	90-042	90-042	90-043	90-043	90-043
49	1/8 SHORT FERRULE (INCLUDED WITH GAS VALVE)	35-1600 (392449)	1 ea.	1 ea.	1 ea.	1 ea.	1 ea.	1 ea.
50	1/8 LONG FERRULE (INCLUDED WITH PILOT ASSEMBLY)	35-1650 (392449-4)	1 ea.	1 ea.	1 ea.	1 ea.	1 ea.	1 ea.
51	KF24 PILOT ORIFICE (NAT GAS) (INCLUDED WITH PILOT ASSY.)		1 ea.	1 ea.	1 ea.	1 ea.	1 ea.	1 ea.
51	K16 PILOT ORIFICE (LP GAS) (INCLUDED WITH PILOT ASSY.)		1 ea.	1 ea.	1 ea.	1 ea.	1 ea.	1 ea.

50MM BURNER COMPONENTS - USED ON INSTALLATIONS ABOVE 2000ft:

60	50mm BURNER WITH PILOT BRACKET	150550	1 ea.	1 ea.	1 ea.	1 ea.	1 ea.	1 ea.
61	50mm BURNER LESS PILOT BRACKET	150551	1 ea.	2 ea.	3 ea.	4 ea.	5 ea.	6 ea.
62	MANIFOLD (50mm BURNERS)	1 ea.	651153	651154	651155	651156	651157	651158
63	ORIFICE SIZE DEPENDS UPON ALTITUDE - CONSULT FACTORY REPRESENTATIVE FOR CORRECT ORIFICE		2 ea.					
63				3 ea.				
63						4 ea.	5 ea.	6 ea.
63	LP GAS ORIFICE (#53 DRILL SIZE)		2 ea.	3 ea.	4 ea.	5 ea.	6 ea.	7 ea.
64	ORIFICE HITCH PIN	950370	2 ea.	3 ea.	4 ea.	5 ea.	6 ea.	7 ea.
65	LOWER INJECTION SHIELD	1 ea.	700503	700504	700505	700506	700507	700508
66	UPPER INJECTION SHIELD	1 ea.	700523	700524	700525	700526	700527	700528
67	1/4-20 BRASS WING NUT		2 ea.	2 ea.	2 ea.	2 ea.	3 ea.	3 ea.
*	10-32 x 3/16" SCREW	146-95-301	2 ea.	2 ea.	2 ea.	2 ea.	2 ea.	2 ea.

* NOT PICTURED

1" Burner Components

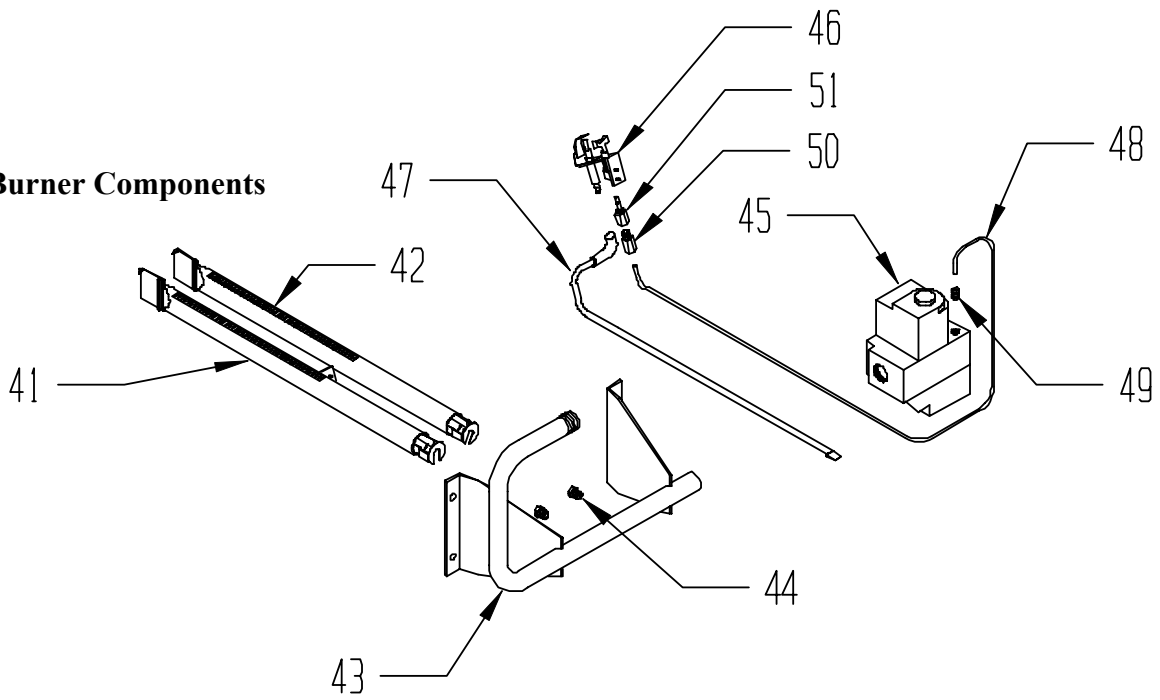

50mm Burner Components

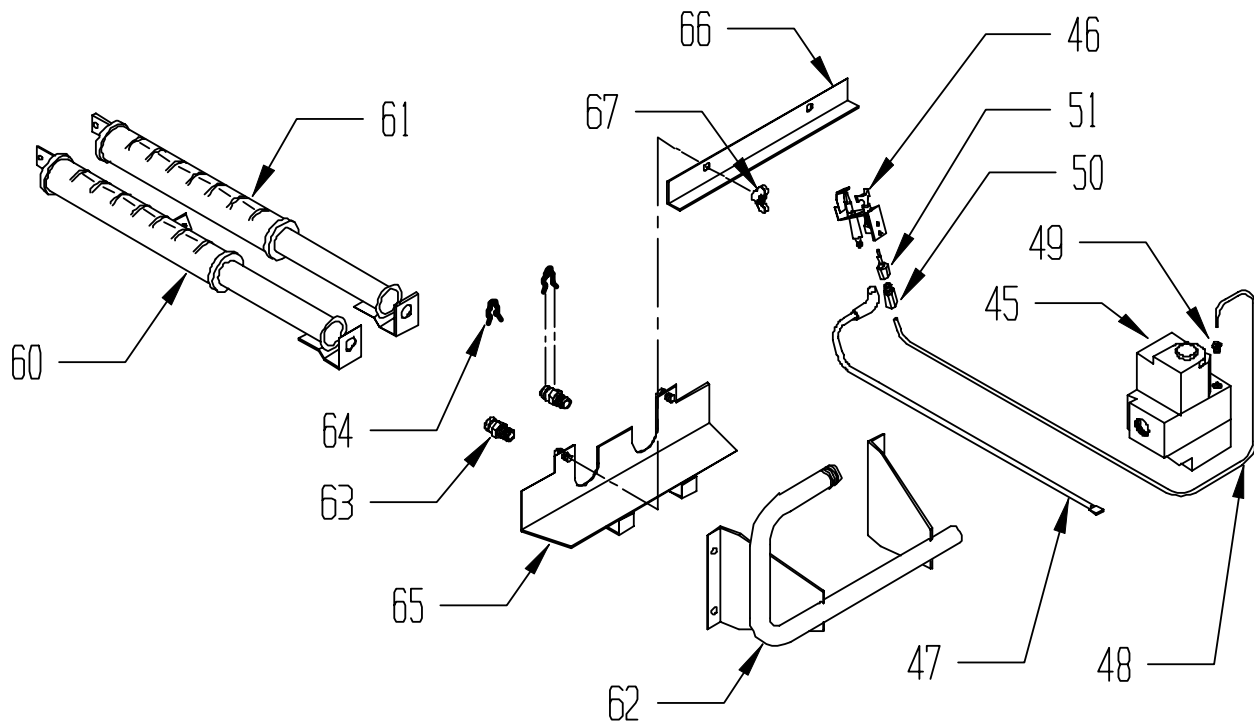

CAUTION

Vacuum switch part numbers shown below for use on boilers
installed at altitudes below 2000 ft.

KEY #	DESCRIPTION	QTY. OR CROWN P.N.	QUANTITY PER BOILER OR CROWN P.N.					
			61	95	128	162	195	229
75	LEFT SIDE JACKET PANEL	650301	1 ea.	1 ea.	1 ea.	1 ea.	1 ea.	1 ea.
76	RIGHT SIDE JACKET PANEL	650300	1 ea.	1 ea.	1 ea.	1 ea.	1 ea.	1 ea.
77	REAR JACKET PANEL	1 ea.	650303	650304	650305	650306	650307	650308
78	TOP JACKET PANEL	1 ea.	650323	650324	650325	650326	650327	650328
79	DOOR	1 ea.	650313	650314	650315	650316	650317	650318
80	INNER PANEL	1 ea.	650333	650334	650335	650336	650337	650338
81	FAN COVER PLATE	60-300	1 ea.	1 ea.	1 ea.	1 ea.	1 ea.	1 ea.
82	JACKET BAR	1 ea.				650346	650347	650348
83	DOOR BRACKET	60-303	2 ea.	2 ea.	2 ea.	2 ea.	2 ea.	2 ea.
84	8-32 X 1/2" SCREW	90-052	6 ea.	6 ea.	6 ea.	6 ea.	6 ea.	6 ea.
85	8-32 NUT	90-053	6 ea.	6 ea.	6 ea.	6 ea.	6 ea.	6 ea.
86	4 X 4 JUNCTION BOX	96-055	1 ea.	1 ea.	1 ea.	1 ea.	1 ea.	1 ea.
87	#10 X 1/2" SHEET METAL SCREW	90-212	24 ea.	24 ea.	24 ea.	24 ea.	24 ea.	24 ea.
88	DOOR KNOB	90-210	2 ea.	2 ea.	2 ea.	2 ea.	2 ea.	2 ea.
89	8-32 X 1/4" H.W.H. SCREW	90-211	2 ea.	2 ea.	2 ea.	2 ea.	2 ea.	2 ea.
90	SEA LEVEL VACUUM SWITCH	1 ea.	650009	650009	650010	650010	650011	650011
91	IGNITION MODULE (S8670E1007)	3505010	1 ea.	1 ea.	1 ea.	1 ea.	1 ea.	1 ea.
92	RELAY (R8222D1022)	3505556	1 ea.	1 ea.	1 ea.	1 ea.	1 ea.	1 ea.
93	FAN CENTER (R8285D5001)	3505555	1 ea.	1 ea.	1 ea.	1 ea.	1 ea.	1 ea.
94	3/4" BOILER DRAIN	95-041	1 ea.	1 ea.	1 ea.	1 ea.	1 ea.	1 ea.
95	CIRCULATOR (TACO 007)	95-012	1 ea.	1 ea.	1 ea.	1 ea.	1 ea.	1 ea.
96	1-1/4" TACO ISOLATION VALVE SET	95-061	1 ea.	1 ea.	1 ea.	1 ea.	1 ea.	1 ea.
97	HIGH LIMIT CONTROL (L4080B1212)	3503400	1 ea.	1 ea.	1 ea.	1 ea.	1 ea.	1 ea.
98	1/2" LONG WELL	35-1006	1 ea.	1 ea.	1 ea.	1 ea.	1 ea.	1 ea.
99	3/4" RELIEF VALVE (30 psi)	95-040	1 ea.	1 ea.	1 ea.	1 ea.	1 ea.	1 ea.
100	TRIDICATOR GAUGE	95-067	1 ea.	1 ea.	1 ea.	1 ea.	1 ea.	1 ea.
*	BWF WIRE HARNESS #1 (MAIN)	1 ea.	9601105	9601105	9601105	9601106	9601106	9601106
*	BWF WIRE HARNESS #2 (BROWN)	9601110	1 ea.	1 ea.	1 ea.	1 ea.	1 ea.	1 ea.
*	BWF WIRE HARNESS #3 (PINK)	9601115	1 ea.	1 ea.	1 ea.	1 ea.	1 ea.	1 ea.
*	BWF WIRE HARNESS #4 (RED)	9601120	1 ea.	1 ea.	1 ea.	1 ea.	1 ea.	1 ea.
*	BWF WIRE HARNESS #5 (ORANGE)	9601125	1 ea.	1 ea.	1 ea.	1 ea.	1 ea.	1 ea.
*	INTERMITTENT IGNITION HARNESS	9601100	1 ea.	1 ea.	1 ea.	1 ea.	1 ea.	1 ea.
*	IGNITION GROUND WIRE HARNESS	9601101	1 ea.	1 ea.	1 ea.	1 ea.	1 ea.	1 ea.

* NOT PICTURED

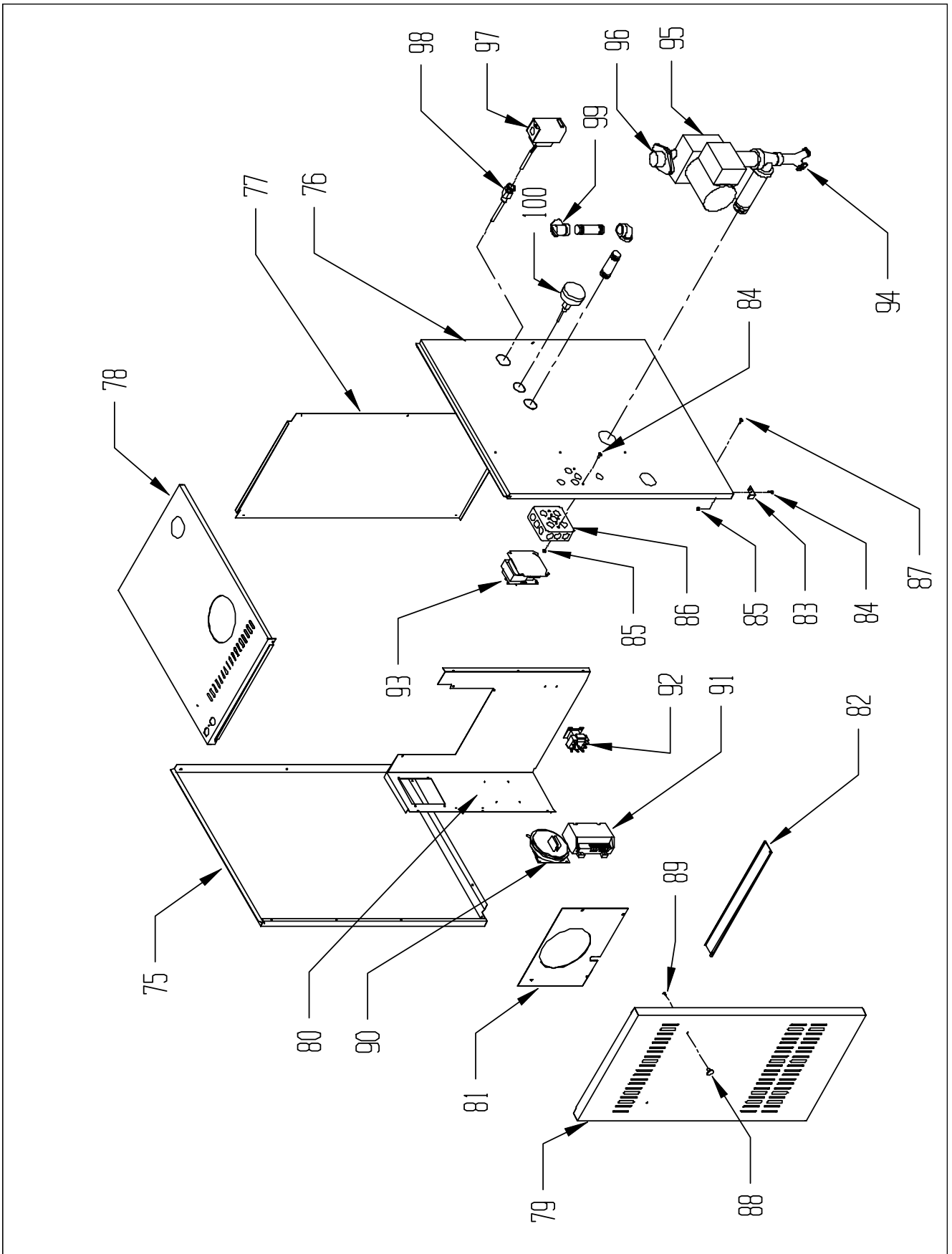

CROWN Boiler Co

Manufacturer of Hydronic Heating Products

P.O. Box 14818 3633 I. Street

Philadelphia, PA 19134

Tel: (215) 535-8900 • Fax: (215) 535-9736 • www.crownboiler.com