

CROWN Boiler Co.

D E S I G N E D T O L E A D

Series 16

Gas-Fired Natural Draft Water Boilers

INSTALLATION AND OPERATING INSTRUCTIONS

These instructions must be affixed on or adjacent to the boiler.

WARNING: Improper installation, adjustment, alteration, service or maintenance can cause property damage, injury, or loss of life. For assistance or additional information, consult a qualified installer, service agency or the gas supplier. Read these instructions carefully before installing.

CROWN
Boiler Co.

Manufacturer of Hydronic Heating Products
P.O. Box 14818 3633 I. Street
Philadelphia, PA 19134



Tel: (215) 535-8900 • Fax: (215) 535-9736 • www.crownboiler.com

Table of Contents

I.	Product Description	1
II.	Specifications	2
III.	Before Installing	3
IV.	Locating the Boiler	3
V.	Knockdown Boiler Assembly Instructions	6
	A. Prior To Assembly	6
	B. Boiler Assembly, Installation & Leak Testing	6
	C. Jacket Assembly	8
	D. Ignition Control & Gas Valve Installation Standard Control System	9
	CSD-1 Control System	9
	E. Control & Trim Installation	12
VI.	Air for Combustion & Ventilation	13
VII.	Venting	17
VIII.	System Piping	21
	A. Heating System Piping	21
	B. Piping for Special Situations	22
IX.	Gas Piping	25
X.	Control System Wiring	26
	A. Standard	27
	B. CSD-1	27
XI.	Start-Up & Checkout	31
XII.	Service & Maintenance	35
XIII.	Parts	37

I Product Description

The Series 16 boiler is a cast iron hot water boiler designed for use in closed forced circulation hot water heating systems found in large homes, multifamily dwellings, small businesses, office complexes and other commercial heating applications. These boilers are Category I draft hood equipped appliances, which must be vented by natural draft using a lined masonry or listed metal chimney system. An adequate supply of air for combustion, ventilation and dilution of flue gases must be available in the boiler room. This boiler is intended for use with natural gas or LP / Propane gas.

II Specifications

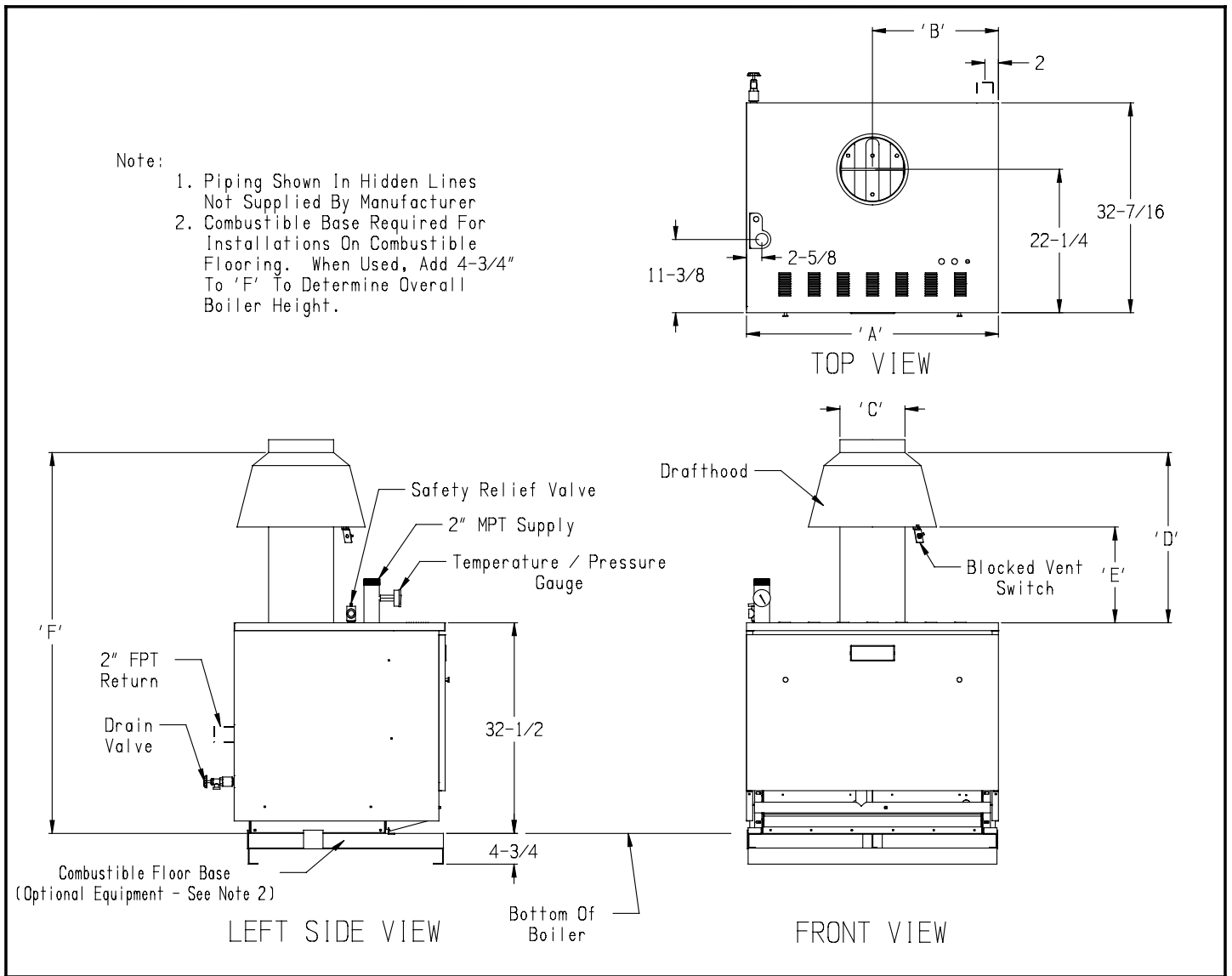

Figure 1: General Configuration

Boiler Model No.	No. Of Sections	Input (BTUH)	D.O.E. Heating Capacity (BTUH)	IBR Net Rating Water (BTUH)	AFUE (%)	Dimensions						Water Content (Gallons)	Approx. Shipping Weight (Lbs)
						A	B	C	D	E	F		
16-325	6	325000	260000	226000	80.0	23-3/4	11-7/8	8	27-13/16	18	60-5/16	13.9	770
16-390	7	390000	312000	271000	80.0	27-1/2	13-3/4	9	28-13/16	18	61-5/16	15.9	875
16-455	8	455000	364000	317000	80.0	31-1/4	15-5/8	9	30-13/16	20	63-5/16	17.9	980
16-520	9	520000	416000	362000	80.0	35	17-1/2	10	33-1/2	22	66	19.9	1080
16-585	10	585000	468000	407000	80.0	38-3/4	19-3/8	10	33-1/2	22	66	21.9	1200

1. Gas connection size = 1" NPT
2. Maximum Allowable Working Pressure: 50 psi (Water Only).
3. Boiler is supplied with 30 psi relief valve.

Table 1: Dimensional Data

III Before Installing

- 1) Safe, reliable operation of this boiler depends upon installation by a professional heating contractor in strict accordance with this manual and the requirements of the authority having jurisdiction.
 - In the absence of an authority having jurisdiction, installation must be in accordance with this manual and the latest edition of the *National Fuel Gas Code*, ANSI Z223.13.
 - Where required by the authority having jurisdiction, this installation must conform to the latest edition of the *Standard for Controls and Safety Devices for Automatically Fired Boilers* (ANSI/ASME CSD-1).
- 2) Make sure that a properly sized chimney is available and is in good condition. Consult the authority having jurisdiction, Part VII of this manual and the *National Fuel Gas Code* for additional information on venting requirements.

Series 16 boilers are equipped with an external draft hood which must be installed without alteration. Make sure adequate head room exists to install Series 16 boiler models with the unaltered draft hood while maintaining proper clearances from the vent connector to combustible materials.
- 3) Make sure that the boiler is correctly sized by utilizing an industry accepted sizing method.
- 4) Make sure that the boiler to be installed is configured for the correct gas (natural or LP).
- 5) Boilers installed at altitudes above 2000 ft. require different main burner orifice than those at sea level. Make sure that the boiler is configured for use at the correct altitude.
- 6) Follow the instructions in Section V to assemble the boiler.

WARNING

This Product Must Be Installed By A Licensed Plumber Or Gas Fitter When Installed Within The Commonwealth Of Massachusetts.

IV Locating the Boiler

- 1) Do not install this boiler directly on a combustible floor. This boiler may be installed over a non-carpeted combustible floor by using the following special bases available from Crown.

<u>Boiler Model</u>	<u>Combustible Flooring Base #</u>
16-325	500506
16-390	500507
16-455	500508
16-520	500509
16-585	500510

- 2) Series 16 clearance and other boiler room space requirements depend upon the size of the boiler:

Models 16-325, 16-390 – These sizes are approved for alcove installation. Install with the minimum clearances shown in Table 2. The clearances shown in Table 2 apply to all combustible construction as well as non-combustible walls, floors, ceilings and doors (also see Figure 2).

Models 16-455, 16-520, 16-585 – These sizes must be installed in a boiler room that is “large in comparison to the boiler”. Such a room is defined as having a volume at least 16 times that of the boiler. Table 3 shows the required minimum boiler room volumes required for these three sizes. To find the volume of the boiler room calculate:

$$\text{Boiler Room Volume (ft}^3\text{)} = \text{Length (ft)} \times \text{Width (ft)} \times \text{Height (ft)}$$

If the boiler room height is greater than 8ft, use 8ft in the above equation.

In addition to the minimum boiler room volume requirement, these three sizes must be installed with the minimum clearances shown in Table 2. The clearances shown in Table 2 apply to all combustible construction as well as non-combustible walls, floors, ceilings and doors (also see Figure 2).

All Models - The following service clearances are recommended from the top and front of the boilers:

- 16-325, 16-390 – 24 inches
- 16-455, 16-520, 16-585 – 48 inches

These clearances may be reduced to those shown in Table 2, however servicing the boiler will become increasingly difficult as these service clearances are reduced.

- 3) The boiler must be installed on a hard level surface.
- 4) Do not install this boiler in a location where gasoline or other flammable vapors or liquids will be stored or used. Do not install this boiler in an area where large amounts of airborne dust will be present, such as a workshop.
- 5) The boiler should be located as close to the chimney as possible.
- 6) Do not install this boiler directly on a surface that may get wet. Raise the boiler on a pad.

<u>Boiler Model</u>	<u>Front</u>	<u>Top</u>	<u>Sides</u>	<u>Rear</u>
16-325 & 16-390	18	36	6	6
16-455, 16-520, 16-585	18	51-1/2	6	6

Clearance between adjacent Series 16 boilers in modular or multiple boiler installation = 1"

Table 2: Minimum Clearances From Boiler To Combustible Material (inches)

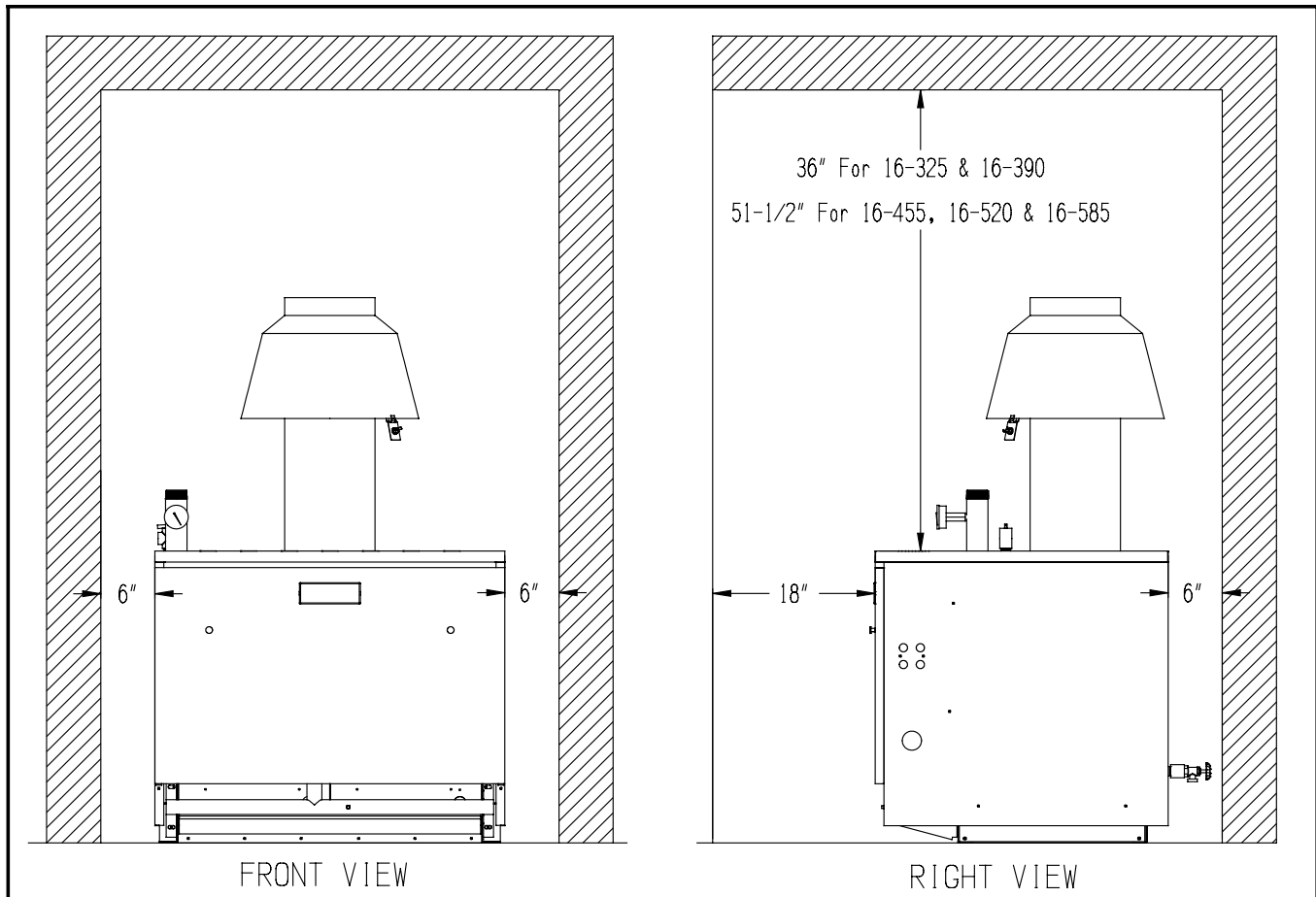

Figure 2: Minimum Clearances to Combustibles

Boiler Model	Over All Length Jacket	Over All Depth Jacket	Over All Height Floor To Top Of Jacket	Boiler Volume (Ft3)	Minimum Room Volume (Ft3)
16-325	23 3/4	32 7/16	32 1/2	14.5	231.8
16-390	27 1/2	32 7/16	32 1/2	16.8	268.4
16-455	31 1/4	32 7/16	32 1/2	19.1	305.0
16-520	35	32 7/16	32 1/2	21.4	341.6
16-585	38 3/4	32 7/16	32 1/2	23.6	378.2

Table 3: Minimum Room Volumes Based On Sixteen Times Boiler Volume By Model Size

V Knockdown Boiler Assembly Instructions

A. Prior To Assembly

- 1) Thoroughly inspect the cast iron heat exchanger for any shipping damage, i.e. cracks in the castings, broken lugs or punctures due to mishandling.
- 2) Do not use a damaged heat exchanger.
- 3) All joints between sections have been factory sealed. Inspect the joints between the sections for openings due as a result of shipping and handling. Reseal any openings with furnace cement.
- 4) All joints between the base and the heat exchanger have been factory sealed. Inspect the joints between the base and the heat exchanger for openings due as a result of shipping and handling. Reseal any openings with furnace cement.
- 5) All joints between the flue collector and the heat exchanger have been factory sealed. Inspect the seal between the flue collector and the heat exchanger for openings due as a result of shipping and handling. Reseal any openings with furnace cement.
- 6) Confirm the tie rods are only hand tight to allow for thermal expansion.
- 7) Review all of the installation requirements in this installation manual.
- 8) Verify that all needed components are on hand. A complete list of all cartons along with their contents can be found in the Parts Section of this manual.

B. Boiler (Base, Heat Exchanger, Flue Collector) Assembly, Installation & Leak Testing

- 1) Each boiler assembly (base, heat exchanger, flue collector combination) is tested and shipped as a single unit.
- 2) Place the base, heat exchanger and flue collector assembly in close proximity to the final location. Refer to Sections III and IV in this manual for additional information on placement.
- 3) Remove all packaging material, protective spacers and bracing from the assembly.
- 4) Remove the base hold down bolts used to anchor the assembly to the skid.
- 5) Exercise care to avoid dropping the boiler while removing it from the skid.
- 6) Leak test the heat exchanger before installing the jacket, trim and controls. Refer to Figure 4 and Table 4 for tapping locations and sizes.
 - a. Plug tappings C, F and return tapping B. Tapping E is plugged at the factory.
 - b. Insert a 3/4" x 1/4" NPT bushing in tapping D and install a pressure gauge with a mid-range of 50 psi in this location.
 - c. Insert a 2" x 3/4" NPT bushing in supply tapping A and install a purge valve with a hose that runs to a drain in this location.
 - d. Connect a fill valve and piping to the drain tapping G.
 - e. Fill the heat exchanger completely with water and vent the air through the purge valve. Slowly close the purge valve and apply water pressure of at least 10 psi but less than 50 psi gauge. **DO NOT EXCEED THE 50 PSI LIMIT.**
 - f. Carefully examine all parts of the heat exchanger assembly for leaks.
 - g. Drain the heat exchanger and remove plugs from tappings B & C. Also remove the fill valve, purge valve pressure gauge and related piping used in the leak test.
- 7) Installation on combustible flooring requires the use of a special base designed and approved for use on combustible floors. See Figure 5. This special base adds 4-3/4" to the overall boiler height. Follow the instructions below if a special base is required.
 - a. Place special base on combustible floor with surface marked "FRONT" in upward position.
 - b. Locate special base with spacing to combustible materials as shown in Figure 5.
 - c. Place the base, heat exchanger and flue collector assembly on the special base. The assembly must rest inside locating brackets. Note that the boiler jacket panels will overhang special base.
 - d. Do not enclose boiler, or special base on all four sides. Models 16-325 and 16-390 may be enclosed on three sides (alcove) while maintaining clearances shown in Figure 2.

- 8) Slide or walk the assembly into its permanent position. **DO NOT DROP.**
- 9) The assembly must be level in both directions and supported around the entire base bottom. Shim and grout under base if necessary.
- 10) The flame roll-out switch has been mounted to the burner access panel at the factory. On boilers with two access panels the panel with the mounted flame roll-out switch should be located on the right. See Figure 4. The flame roll-out switch is a single use device - do not test with heat - the switch cannot be reset.
- 11) Remove the immersion well from the Combination Boiler Parts and Control Carton. Insert the immersion well in tapping D. See Figure 4. If a second limit or operating control is used, it is recommended that it be installed in the near boiler supply piping.

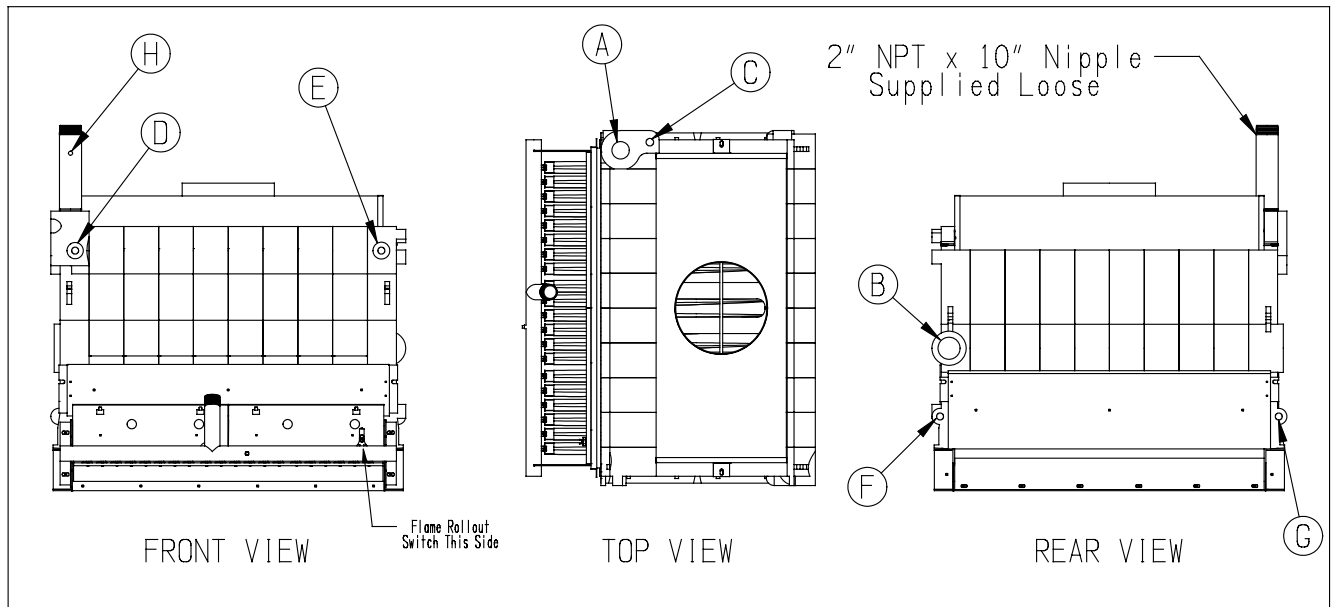

Figure 4: Boiler Shipping Arrangement With Tapping Locations

Component Description	Tapping Location	Tapping Size (in)
Supply Piping	A	2
Return Piping	B	2
Pressure Relief Valve	C	3/4
Honeywell L4080D Limit Control	D	3/4
Factory Plugged	E	3/4
Washout (Factory Plugged)	F	3/4
Boiler Drain Valve	G	3/4
Combination Pressure / Temperature / Altitude Gauge	H	1/4
Honeywell L4006E Manual Reset Limit Control (By Others)	Boiler Supply Piping	-
Low Water Cut Off (By Others)	Boiler Supply Piping	-

Table 4: Tapping Purpose Chart

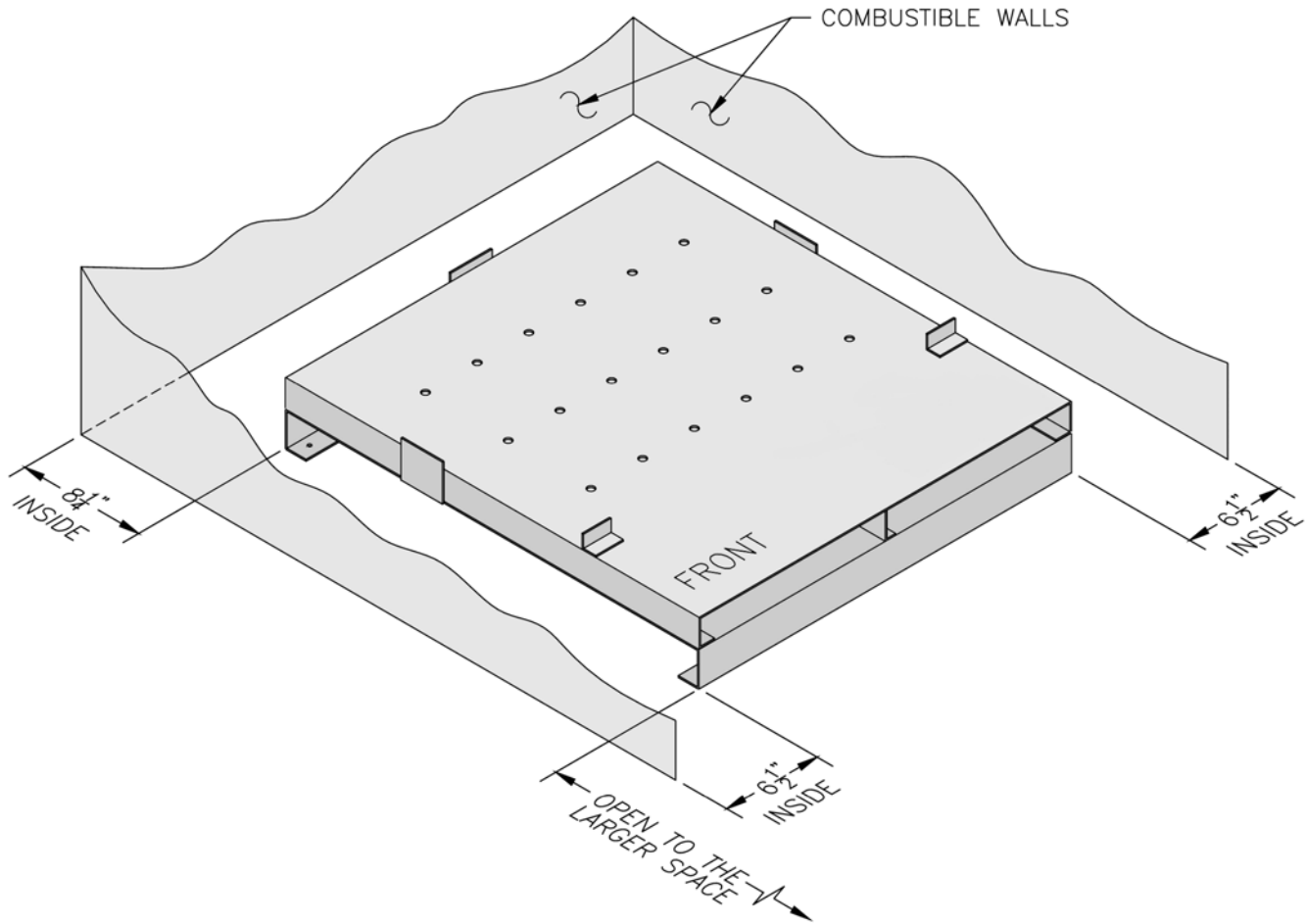

Figure 5: Installation of Combustible Flooring Base

C. Jacket Assembly

NOTE

Before installing the jacket, make sure to plug any tappings which are not going to be used. Also make sure that no tappings are plugged which will be needed later for piping the boiler. See Section VIII for system piping.

- 1) Align the left jacket side panel with the screw holes located on the upper flange of the left base end panel and loosely attach the left jacket side panel with two #10 x 1/2" sheet metal screws as shown in Figure 6.
- 2) Repeat Step 1 for the right side panel.
- 3) Insert the left and right sides of the jacket rear panel behind the rear flange located on the left and right jacket side panels and loosely attach it to the side panels using eight #10 x 1/2" sheet metal screws (four per side) as shown in Figure 6.
- 4) On the front of the boiler insert the jacket vestibule panel between the left and right jacket side panels. Align the screw holes located on the side flanges of the jacket vestibule panel with the screw clearance holes on both the side panels and loosely attach the vestibule panel with four #10 x 1/2" sheet metal screws (two per side) as shown in Figure 6.

- 5) Lay the jacket top panel on top of the jacket side and rear panels. Locate the top of the rear jacket panel to the inside of the jacket top panel. Align the sides of the jacket top panel to be flush with the outside of the jacket side panels. Loosely attach the rear flange of the jacket top panel to the jacket rear panel using three #10 x 1/2" sheet metal screws. On the inside front of the boiler, attach the jacket top panel to the jacket side panels with two #10 x 1/2" sheet metal screws (one per side) as shown in Figure 6.
- 6) Return to the loosely installed sheet metal screws and tighten all screws.
- 7) Attach the four door mounting hardware clips (two per side) to the front end of the left and right side panels with #8-32 x 1/2" machine screws.
- 8) Attach the door knobs to the jacket door panel with 8-32 x 1/4" machine screws.
- 9) Mount the jacket door panel to the front of the boiler.

D. Ignition Control & Gas Valve Installation Standard (Honeywell S8610M) Control System

- 1) The standard gas valve assembly has been pre-piped with one half of a piping union and is to be connected to the other half of the union located on the gas manifold. See Figure 7.
- 2) This connection must be leak tested before placing the boiler in operation. See Section IX for further instructions on leak testing the gas piping.
- 3) Connect the pilot tubing from the pilot burner to the gas valve pilot tapping.
- 4) Attach the ignition module bracket to the jacket vestibule panel using (2) #10 x 1/2" sheet metal screws. See Figure 6.
- 5) Attach the Honeywell S8610M ignition control module to the ignition module base using (4) #8 x 1/2" sheet metal screws.
- 6) Connect the green ground wire from the pilot assembly to terminal number 4 (Burner GND) on the ignition control module.
- 7) Connect the orange ignitor wire from the pilot assembly to terminal number 9 (SPARK) on the ignition control module.
- 8) Refer to Section X for complete wiring instructions.

E. Ignition Control & Gas Valve Installation CSD-1 Control System

- 1) The CSD-1 gas valve assembly has been pre-piped with one half of a piping union and is to be connected to the other half of the union located on the gas manifold. See Figure 8.
- 2) This connection must be leak tested before placing the boiler in operation. See Section IX for further instructions on leak testing the gas piping.
- 3) Connect the pilot tubing from the pilot burner to the pilot solenoid valve located on the CSD-1 gas valve assembly.
- 4) Attach the ignition module bracket to the jacket vestibule panel using (2) #10 x 1/2" sheet metal screws. See Figure 6.
- 5) Attach the UT 1003-612A ignition control module to the ignition module base using (4) #8 x 1/2" sheet metal screws.
- 6) Attach the UT daughter board mounting bracket to the jacket vestibule panel using (2) #10 x 1/2" sheet metal screws.
- 7) Attach the UT 1145-2 daughter board to the daughter board mounting bracket using (2) #8-32 x 1/2 screws and hex nuts.
- 8) Connect the green ground wire from the pilot assembly to the terminal marked 24V GND on the ignition control module.
- 9) Connect the orange ignitor wire from the pilot assembly to the terminal marked SPARK on the ignition control module.
- 10) Refer to Section X for complete wiring instructions.
- 11) Apply the 'CSD-1' wiring label over top of the 'Standard' wiring label located on the inside door panel.

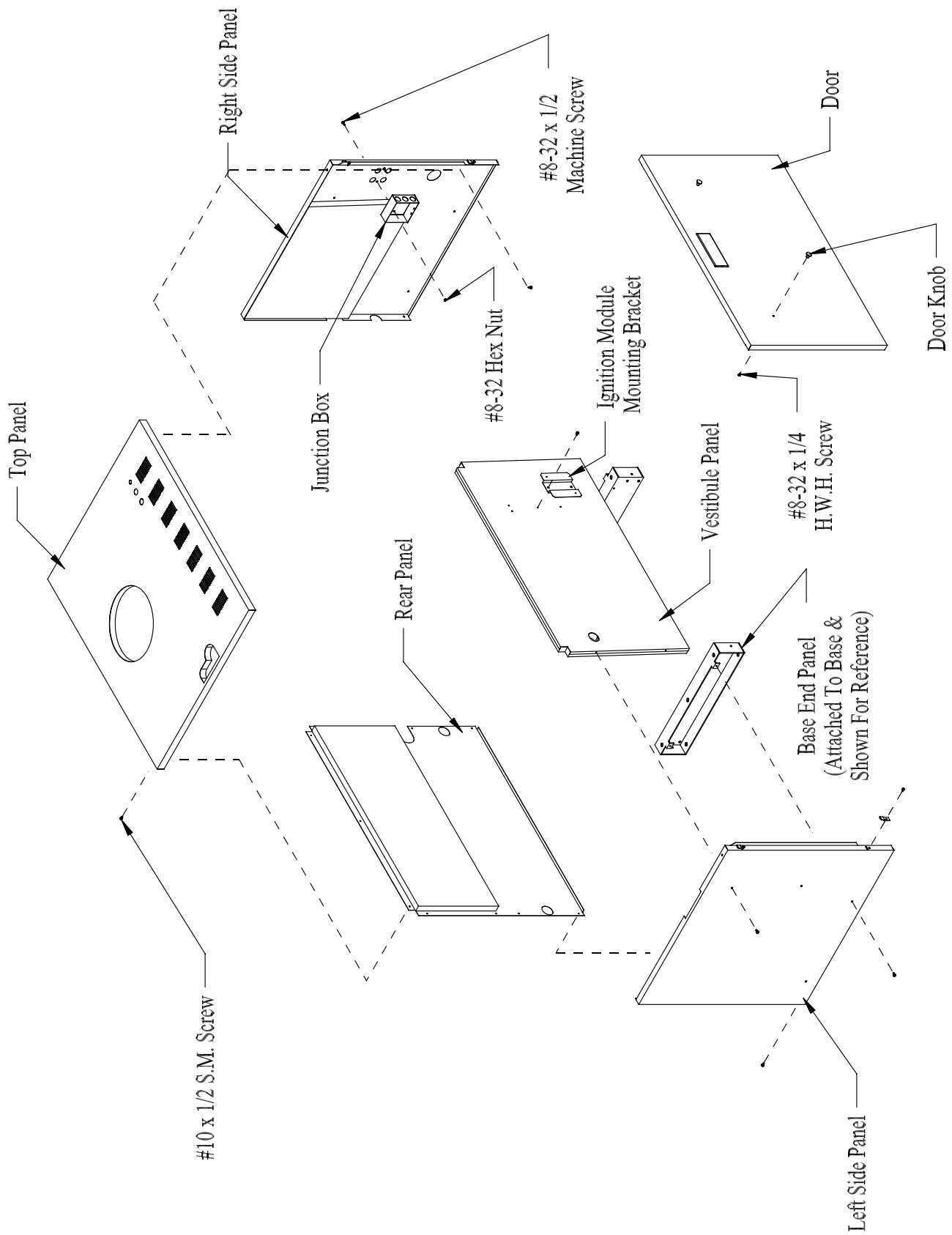

Figure 6: Jacket Assembly

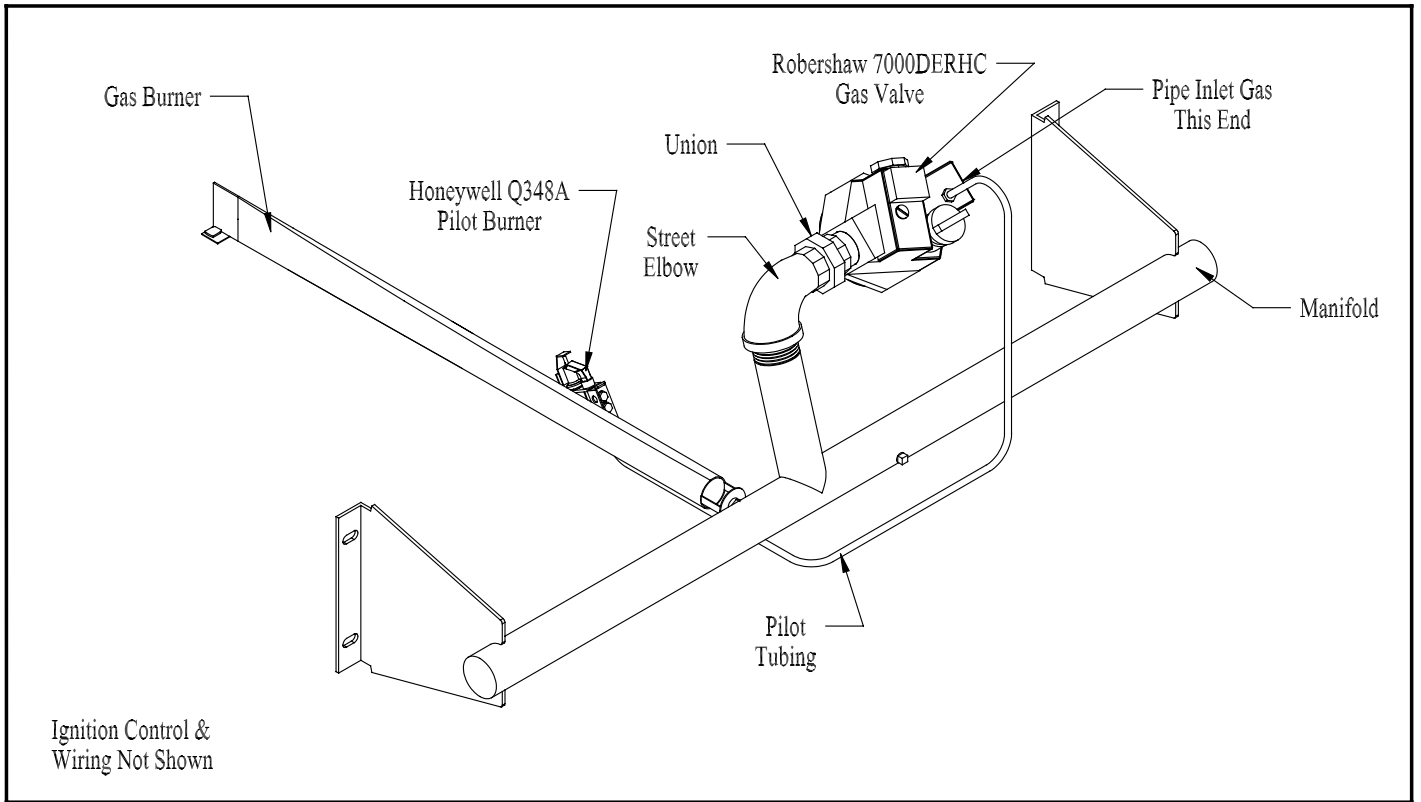

Figure 7: Gas Train - Standard Build

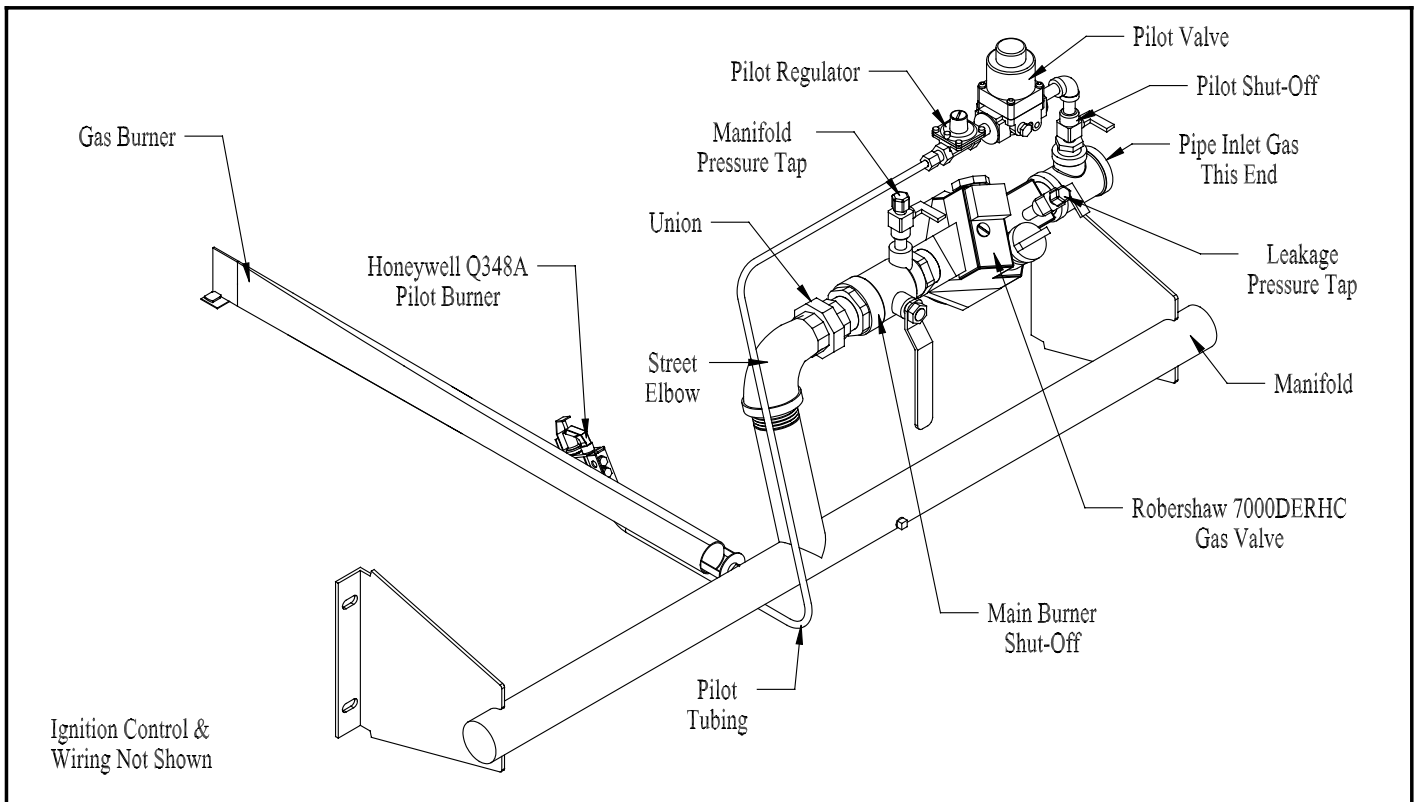

Figure 8: Gas Train - CSD-1 Build, 16-455, 16-520,& 16-585

F. Control & Trim Installation

- 1) Table 4 shows the use of all tapings on Series 16 boilers. The tapping letter designations referenced are shown in Figure 4. Control and trim components are as follows:
 - a. 4 x 4 Junction Box - Install the supplied junction box on the inside of right jacket side panel with two 8-32 x 1/2" machine screws and nuts. See Figure 6.
 - b. R8285D Control Center is to be mounted to the 4 x 4 junction box. Refer to Section X for complete wiring instructions.
 - c. Temperature-Pressure Gauge - Install the T&P gauge in tapping "H". Tapping "H" is located on the supplied 2" NPT x 10" supply nipple (See Figure 9). **DO NOT TIGHTEN THE GAUGE BY ITS CASE.**
 - d. L4080D Operating Limit Control - Insert the bulb of the control into the well until it rests against the bottom of the well. Bend the tubing if necessary to provide enough force to hold the bulb against the bottom of the well. Avoid making a sharp bend in the tubing as this can cause the control to malfunction. Tighten the screw on the bottom of the control so that it is securely clamped onto the well.

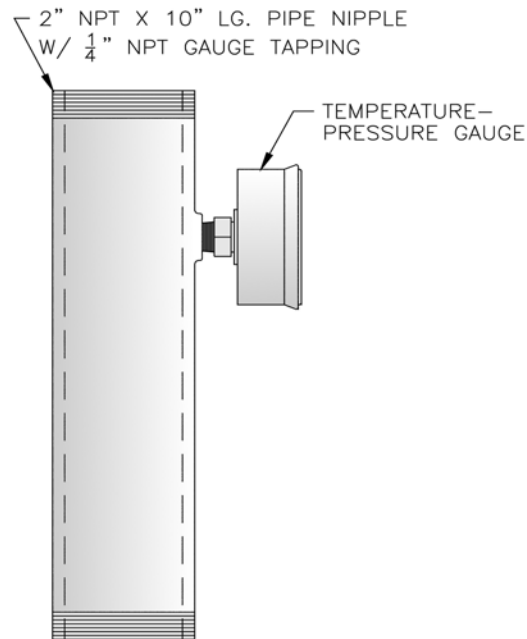

Figure 9: Temperature-Pressure Gauge Installation

VI Air For Combustion and Ventilation

Sufficient fresh air must be supplied for combustion, ventilation and flue gas dilution. Provisions for combustion, ventilation and flue gas dilution air for gas utilization equipment vented by natural draft must be made in accordance with local building codes or, in absence of such codes, in accordance with the *National Fuel Gas Code*, NFPA 54/ANSI Z223.1.

Warning

An adequate supply of combustion and ventilation air must be provided to assure proper combustion.

- 1) Start by determining whether the boiler is to be installed in a building of conventional construction or of unusually tight construction. A good definition of a building of unusually tight construction is one which has all of the following features:
 - Walls and ceilings exposed to outside atmosphere have a continuous water vapor retarder with a rating of 1 perm or less with openings gasketed and sealed.
 - Weather stripping has been added on openable windows and doors.
 - Caulking and sealants are applied to areas such as joints around window and door frames, between sole plates and floors, between wall-ceiling joints, between wall panels, at penetrations for plumbing, electrical, and gas lines, and at other openings.
- 2) Determine the volume of the boiler room space. Rooms communicating directly with the boiler room space, in which the fuel burning appliances are installed, through openings not furnished with doors, are considered a part of the boiler room space.

$$\text{Volume (ft}^3\text{)} = \text{Length (ft)} \times \text{Width (ft)} \times \text{Height (ft)}$$

In calculating the volume of the boiler room, consider the volume of adjoining spaces only if no doors are installed between them. If doors are installed between the boiler room and an adjoining space, do not consider the volume of the adjoining space, even if the door is normally left open.

- 3) Determine total input of all fuel burning appliances in the boiler room space. Add inputs of all fuel burning appliances in the boiler room space and round the result to the next highest 1000 Btu per hour.
- 4) Determine type of boiler room space to be used. Divide Volume by Total Input (in MBH) of all fuel burning appliances in the boiler room space. If the result is greater than or equal to 50 ft³/MBH, then it is considered a **unconfined space**. If the result is less than 50 ft³/MBH, then the boiler room space is considered a **confined space**.

A. For Buildings Not Of Unusually Tight Construction

- 1) **Unconfined space** - Fresh air infiltration through cracks and around windows and doors normally provides adequate air for combustion and ventilation without additional louvers or openings into the boiler room.
- 2) **Confined space** - Provide two openings into the boiler room, one near the floor and one near the ceiling. The top edge of the upper opening must be within 12" of the ceiling and the bottom edge of the lower opening must be within 12" of the floor. See Figure 10.
 - Each opening must have a free area of 1 square inch per 1000 BTU/hr input of all gas burning appliances in the boiler room. The minimum opening dimension is 3 inches. Minimum opening free area is 100 square inches per opening.
 - If the total volume of both the boiler room and the room to which the openings connect is less than 50 cubic feet per 1000 BTU/hr of total appliance input, install a pair of identical openings into a third room. Connect additional rooms with openings until the total volume of all rooms is at least 50 cubic feet per 1000 BTU/hr of input.
 - The "free area" of an opening takes into account the blocking effect of mesh, grills, and louvers. Where screens are used, they must be no finer than 1/4" (4 x 4) mesh.

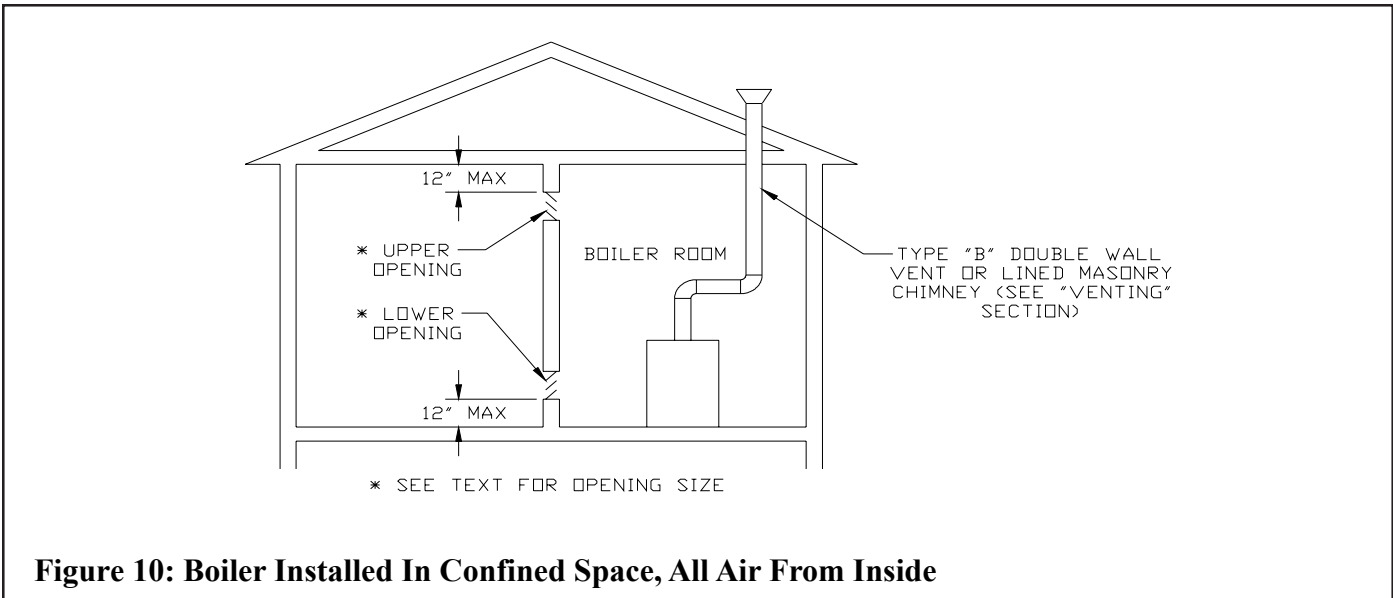

Figure 10: Boiler Installed In Confined Space, All Air From Inside

- If providing openings into adjacent rooms is undesirable, combustion and ventilation air can be brought into the boiler room from outdoors. See the instructions under **“For Buildings of Unusually Tight Construction”**.

B. For Buildings Of Unusually Tight Construction

- 1) Provide outdoor air through two permanent openings which communicate directly or by duct with the outdoors or spaces (crawl or attic) freely exchanging air with the outdoors. The top edge of the upper opening must be within 12” of the ceiling and the bottom edge of the lower opening must be within 12” of the floor. The minimum dimension of each air opening is 3 inches. Size each opening per the following instructions:
 - a. **Direct communication with outdoors** (Figure 13) require a minimum free area of 1 square inch per 4,000 Btu per hour input based on all fuel burning appliances in the boiler room space but not less than 100 square inches. The minimum opening size is 3 inches.
 - b. **Vertical ducts or Openings** (Figure 11 and Figure 12) require a minimum free area of 1 square inch per 4,000 Btu per hour input of all fuel burning appliances in the boiler room space but not less than 100 square inches. The cross-sectional area of the duct shall be the same as the required free area opening. The minimum opening size is 3 inches.
 - c. **Horizontal ducts** to the outdoors (Figure 14) require a minimum free area of 1 square inch per 2,000 Btu per hour input of all fuel burning appliances in the boiler room space but not less than 100 square inches. The cross-sectional area of the duct shall be the same as the required free area opening. The minimum opening size is 3 inches.
 - d. **Louvers and Grilles of Ventilation Ducts** - All outside openings should be screened or louvered. Louvers will prevent the entrance of rain and snow. Louvers and grilles must be fixed in the open position. If motorized louvers are used, they must be interlocked to prevent boiler operation in the event the louvers do not fully open.

Important

When determining the “free area” of an opening, the blocking effects of mesh screens, grills, louvers and the like should be taken into account. Where screens are used, they must be no finer than 1/4” (4 x 4) mesh.

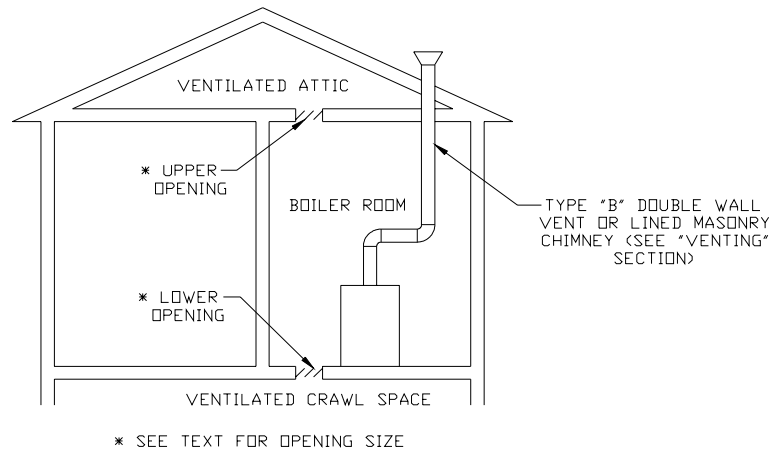

Figure 11: All Air From Outdoors, Ventiladed Crawl Space & Attic

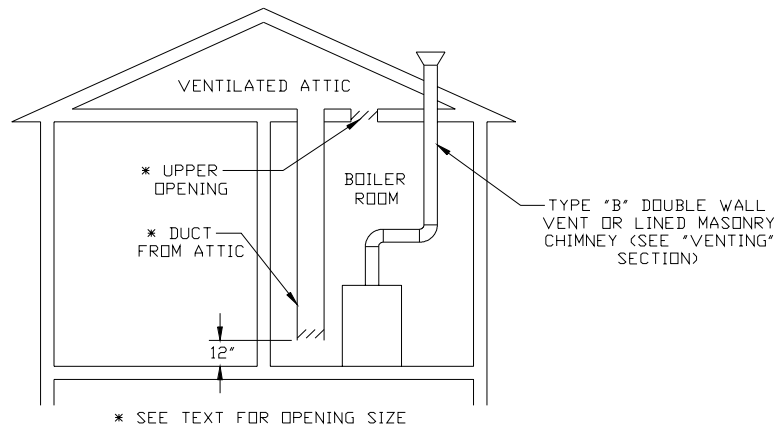

Figure 12: All Air From Outdoors, Via Ventiladed Attic

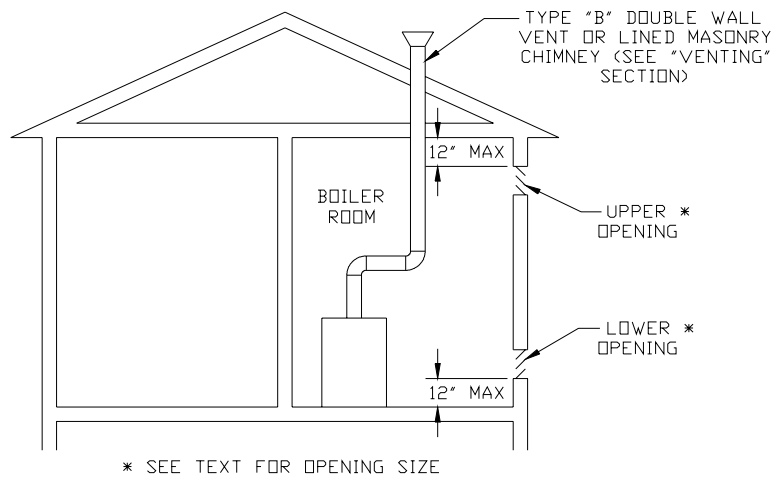
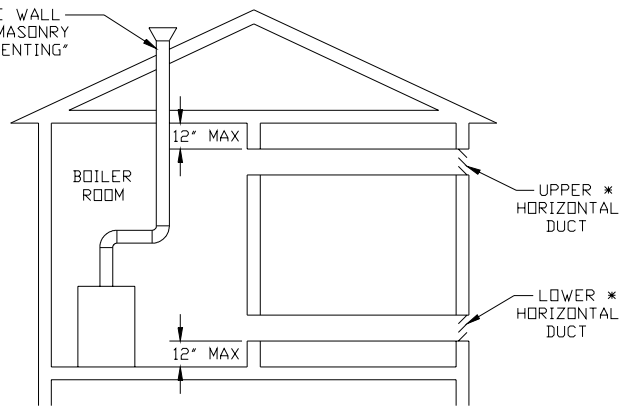

Figure 13: All Air From Outdoors, Using Openings Into Boiler Room

TYPE "B" DOUBLE WALL
VENT OR LINED MASONRY
CHIMNEY (SEE "VENTING"
SECTION)



* SEE TEXT FOR OPENING SIZE

Figure 14: All Air From Outdoors, Using Horizontal Ducts Into The Boiler Room

VII Venting

Vent installation must be in accordance with local building codes, or the authority having jurisdiction, or Chapters 7 and 10 of the *National Fuel Gas Code*, NFPA 54/ANSI Z223.1.

A typical vent installation is shown in Figure 15. The components of a vent installation are the draft hood, vent damper (optional), vent connector and chimney.

- 1) Acceptable Chimneys - The following chimneys may be used to vent Series 16 boilers:
 - Listed Type B or L gas vent - Install in accordance with the manufacturer's instructions, the terms of its listing, and applicable codes.
 - Masonry Chimney - The masonry chimney must be constructed in accordance with the *Standard for Chimneys, Fireplaces, Vents, and Solid Fuel Burning Appliances* (NFPA 211) and lined with a clay liner or other listed lining system. Do not vent a Series 16 boiler into an unlined chimney.
- 2) Acceptable Vent Connectors - The following may be used for vent connectors:
 - Listed type B or L Gas Vent
 - Single Wall Galvanized Pipe - Use 0.018" (26 gauge or heavier). The size and location of the chimney may not permit the use of a single wall connector in some cases. See Chapter 10 of the *National Fuel Gas Code*. Do not use single wall pipe for vent connectors in attics.
 - Other Vent Connectors Permitted by the *National Fuel Gas Code*.
- 3) Chimney and Vent Connector Sizing – Size the chimney and vent connector in accordance with the *National Fuel Gas Code*.
- 4) Exterior Chimneys - An exterior chimney has one or more sides exposed to the outdoors below the roof line. There are two conditions under which an exterior chimney may be used:
 - In some very restrictive cases, Series 16 boilers may be vented into an exterior ceramic lined masonry chimney. See the *National Fuel Gas Code* for information on when exterior chimneys may be used.
 - An exterior masonry chimney may be used if it is lined with B vent or a listed chimney lining system.
- 5) This boiler may be vented using a listed power venter. The power venter must be sized and installed in accordance with the power venter manufacturer's instructions, the terms of the power venter listing, and applicable codes. The boiler must be electrically interlocked with the power venter to prevent boiler operation if the power venter fails to operate. Before deciding to use a power venter, make certain that the flue gas exiting the power venter will not damage adjacent construction or other structures. Also make certain that the power venter terminal will not be subjected to winds which could effect power venter operation. The factory supplied draft hood must still be installed and may not be altered. See Figure 9.
- 6) Do not connect the vent of this appliance into any portion of a mechanical vent system operating under positive pressure.
- 7) Do not connect the boiler into a chimney flue serving an open fireplace or other solid fuel appliance.
- 8) Prior to boiler installation, inspect chimney for obstructions or other defects and correct as required. Clean chimney as necessary.

Warning

Do not attempt to cut or otherwise alter the draft hood supplied with the Series 16 boiler. Do not mount the draft hood in a position other than that shown in Figure 15. Doing either of these things could create a Carbon Monoxide hazard.

- 9) Series 16 boilers are supplied with an external draft hood which must be installed as shown in Figure 15 **without alteration**. Before installing the draft hood, verify that the model number marked on the draft hood matches that of the boiler being installed. Prior to securing the draft hood verify that the distance from the top of the jacket to the bottom of the draft hood skirt matches dimension 'E' in Figure 1. Secure the draft hood to the boiler with at least three screws.
- 10) Vent pipe should slope upwards from the draft hood not less than one inch in four feet. No portion of vent pipe should run downward or have sags. Vent pipe must be securely supported.
- 11) Vent pipe should be installed above the bottom of the chimney to prevent blockage.
- 12) Vent pipe must be inserted flush with inside face of the chimney liner and the space between vent pipe and chimney sealed tight.

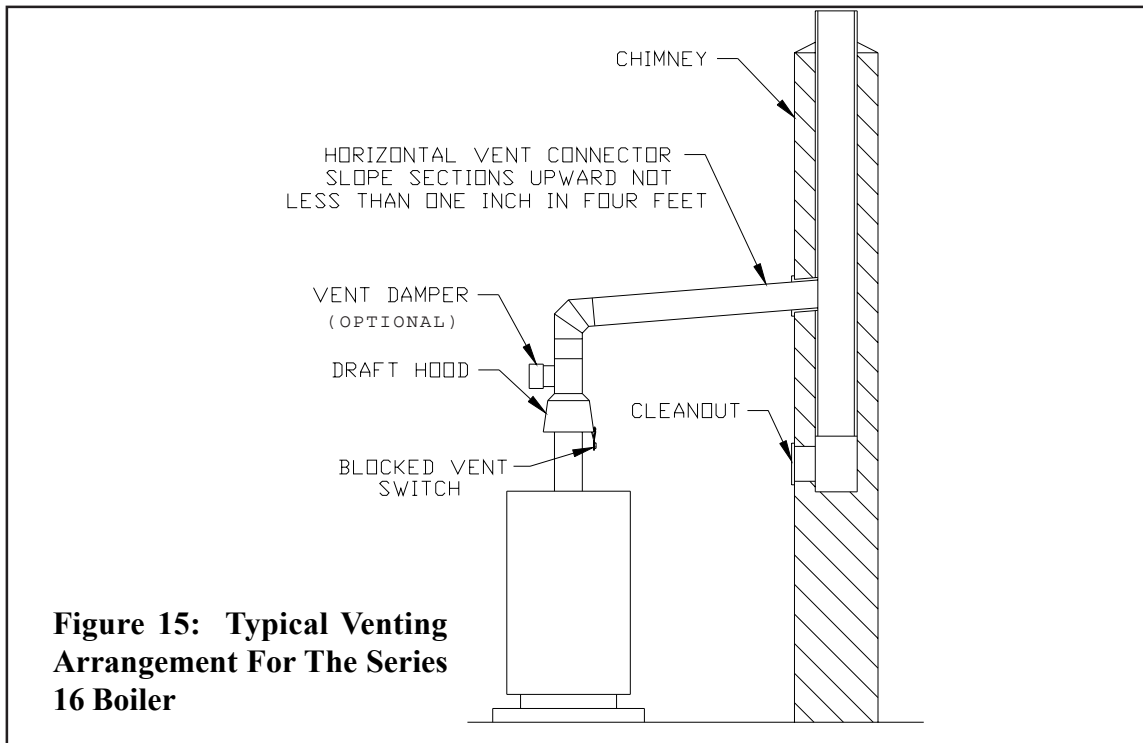

- 13) On all Series 16 boiler models install the blocked vent switch assembly to the supplied external draft hood. See Figure 16. The assembly consists of power cord and switch attached to mounting bracket and is shipped taped to the top of boiler jacket. The procedure is outlined below:
 - a) Untape blocked vent switch assembly from top of boiler. Uncoil power cord.
 - b) Position mounting bracket onto lower edge of draft hood skirt. Locate center tooth (with #10 sheet metal screw) on outside and other two teeth inside draft hood skirt. See Figure 16.
 - c) Slide mounting bracket tight against lower edge of draft hood skirt. Position #10 sheet metal screw above skirt's stiffening rib.
 - d) Secure bracket in position by tightening #10 sheet metal screw against outer surface of draft hood skirt.
 - e) Make sure that there is no slack in the power cord between the cable clamp on the junction box and the blocked vent switch on the draft hood.
 - f) Verify power cord, mounting bracket and blocked vent switch are secure and located as shown in Figure 16.
- 14) Do not install the optional vent damper in any portion of the vent system which is used by appliances other than the boiler being installed.
- 15) Vent damper installation is optional on all Series 16 model boilers. When used, install the vent damper (Figure 17) as follows:
 - a) Open vent damper carton and remove installation instructions. Read the instructions thoroughly before proceeding. Verify that vent damper is same size as draft diverter outlet. See Figure 1. Unpack vent damper carefully. **Do not force closed damper blade.** Forcing vent damper closed may result in damaged gear train and void warranty.

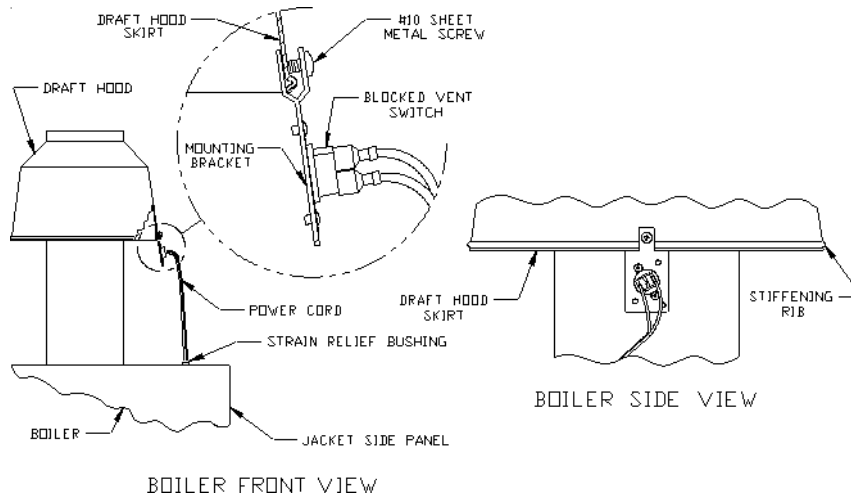

Figure 16: Blocked Vent Switch Installation Details

- b) Vent damper is factory shipped having approximately $\frac{3}{4}$ " diameter hole in the vent damper blade, which **must be left open** for boilers equipped with standing pilot, and should be plugged on boilers with an intermittent pilot, using the plug supplied with the damper. Mount the vent damper on the flue collar without modification to either and secure with sheet metal screws. Make sure screws do not interfere with damper blade operation. Vent damper blade position indicator must be visible to users.
- c) The damper wire harness is shipped loose. One end of the harness is provided with a quick connect fitting and the other end of the harness is provided with a connector nut. Attach the end with the connector nut to the top jacket panel using one of the $\frac{1}{2}$ " knockouts and plug the polarized connectors together. At the vent damper, plug the loose end of the harness into the damper and attach the quick connector to the bracket on the vent damper motor.
- d) Install vent connector pipe and vent fittings from vent damper outlet to chimney or gas vent. Secure with sheet metal screws and support as required.

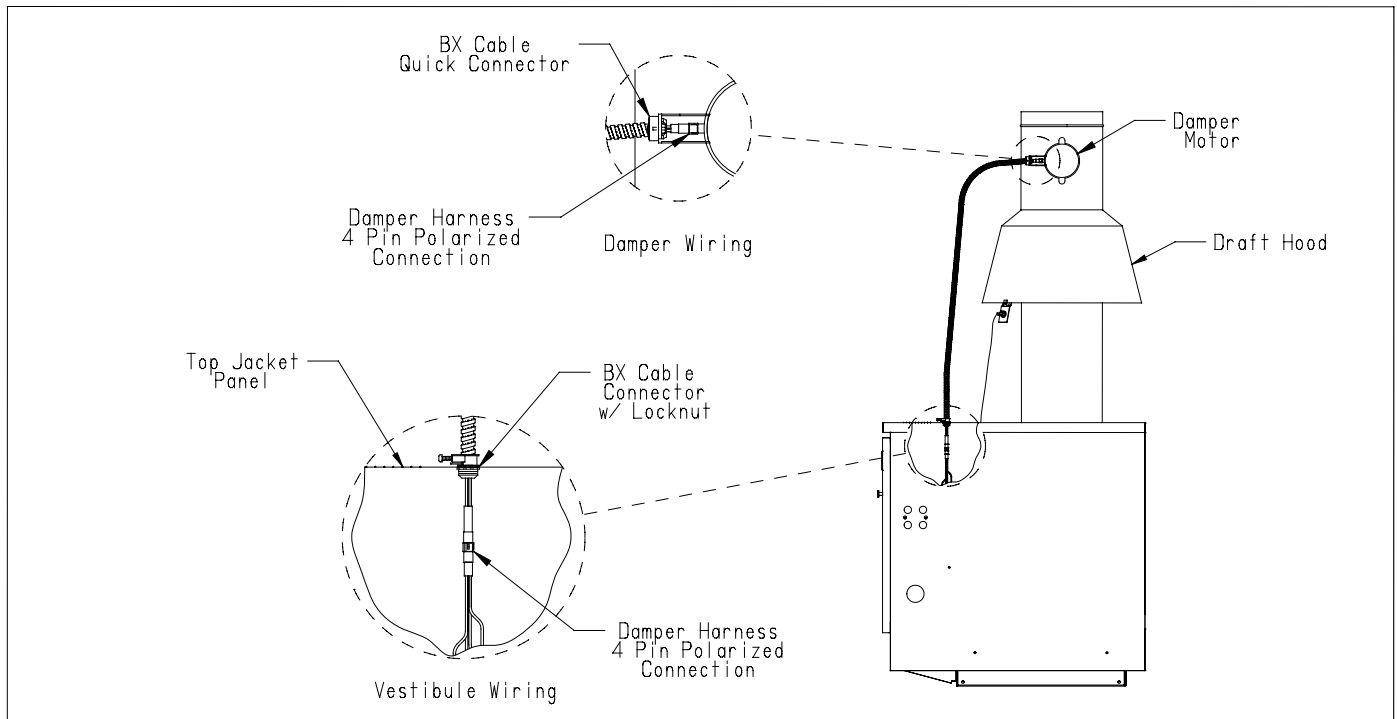

Figure 17: Vent Damper Installation Details

Removing An Existing Boiler From A Common Chimney

In some cases, when an existing boiler is removed from a common chimney, the common venting system may be too large for the remaining appliances. At the time of removal of an existing boiler, the following steps shall be followed with each appliance remaining connected to the common venting system placed in operation, while the other appliances remaining connected to the common venting system are not in operation.

- a) Seal any unused opening in the common venting system.
- b) Visually inspect the venting system for proper size and horizontal pitch and determine there is no blockage or restriction, leakage, corrosion and other deficiencies which could cause an unsafe condition.
- c) Insofar as practical, close all building doors and windows and all doors between the space in which all the appliances remaining connected to the common venting system are located and other spaces of the building. Turn on clothes dryers and any appliance not connected to the common venting system. Turn on any exhaust fans, such as range hoods and bathroom exhausts, so they will operate at maximum speed. Do not operate a summer exhaust fan. Close fireplace dampers.
- d) Place in operation the appliance being inspected. Follow the lighting instructions. Adjust thermostat so the appliance will operate continuously.
- e) Test for spillage at the draft hood relief opening after five (5) minutes of main burner operation. Use the flame of a match or candle, or smoke from a cigarette, cigar, or pipe.
- f) After it has been determined that each appliance remaining connected to the common venting system properly vents when tested as outlined above, return doors, windows, exhaust fans, fireplace dampers and any other gas-burning appliances to their previous condition of use.
- g) Any improper operation of the common venting system should be corrected so the installation conforms with the National Fuel Gas Code, ANSI Z223.1. When resizing any portion of the common venting system, the common venting system should be resized to approach the minimum size as determined using the appropriate tables in Part 11 of the National Fuel Gas Code, ANSI Z223.1.

VIII System Piping

CAUTION

- INSTALL BOILER SO THAT THE GAS IGNITION SYSTEM COMPONENTS ARE PROTECTED FROM WATER (DRIPPING, SPRAYING, RAIN, ETC.) DURING APPLIANCE OPERATION AND SERVICE (CIRCULATOR REPLACEMENT, ETC.).
- OPERATION OF THIS BOILER WITH CONTINUOUS RETURN TEMPERATURES BELOW 120°F CAN CAUSE SEVERE HEAT EXCHANGER CORROSION DAMAGE.
- OPERATION OF THIS BOILER IN A SYSTEM HAVING SIGNIFICANT AMOUNTS OF DISSOLVED OXYGEN CAN CAUSE SEVERE HEAT EXCHANGER CORROSION DAMAGE.
- DO NOT USE TOXIC ADDITIVES, SUCH AS AUTOMOTIVE ANTIFREEZE, IN A HYDRONIC SYSTEM.

A. Standard Heating System Piping

- 1) Figure 18 shows typical boiler system connections on a single zone system. Additional information on hydronic system design may be found in *Installation of Residential Hydronic Systems* (Pub. #200) published by the Hydronics Institute in Berkeley Heights, NJ. The components in this system and their purposes are as follows:
 - a. Relief valve (Required) - Install a 3/4" NPT x 3-1/2" lg. nipple in tapping "C" located on the left side of the boiler. Mount the relief valve on the end of the nipple as shown in Figure 1. The relief valve shipped with the boiler is set to open at 30 psi. This valve may be replaced with one having a pressure up to the "MAWP, WATER" shown on the rating plate. If the valve is replaced, the replacement must have a relief capacity in excess of the DOE heating capacity for the boiler.

Pipe the discharge of the relief valve to a location where water or steam will not create a hazard or cause property damage if the valve opens. The end of the discharge pipe must terminate in an unthreaded pipe. If the relief valve discharge is not piped to a drain it must terminate at least 6 inches above the floor. Do not run relief valve discharge piping through an area that is prone to freezing. The termination of the relief valve discharge piping must be in an area where it is not likely to become plugged by debris.

DANGER

- PIPE RELIEF VALVE DISCHARGE TO A SAFE LOCATION.
- DO NOT INSTALL A VALVE IN THE RELIEF VALVE DISCHARGE LINE.
- DO NOT MOVE RELIEF VALVE FROM FACTORY LOCATION.
- DO NOT PLUG RELIEF VALVE DISCHARGE.

- b. Drain Valve (Required) - Install a 3/4" NPT x 3-1/2" nipple in tapping "G" located in the rear of the left end section of the boiler. Attach a 3/4" NPT pipe coupling to the end of the nipple and attach the drain valve to the end of the coupling.
- c. Circulator (Required) - The best circulator location is usually on the supply piping just downstream of the expansion tank as shown in Figure 18.
- d. Expansion Tank (Required) - If the expansion tank must be replaced, consult the expansion tank manufacturer's literature for proper sizing.
- e. Fill Valve (Required) - Either a manual or automatic fill valve may be used. The ideal location for the fill is at the expansion tank. On large systems with an automatic fill valve, it is recommended that a small water meter be installed in the make-up water line to monitor the amount of water added to the system.
- f. Automatic Air Vent (Required) - At least one automatic air vent is required and should be located at the expansion tank. Manual vents will usually be required in other parts of the system to remove air during initial fill.
- g. Low Water Cut-Off (Required in some situations) - A low water cutoff is required when the boiler is installed above radiation. In addition, some codes such as ASME CSD-1 require low water cutoffs. Codes may also require that

this low water cutoff have a manual reset function. The low water cutoff may be a float type or probe type, but must be designed for use in a hot-water system. The low water cutoff should be piped into the boiler supply just above the boiler with no intervening valves between it and the boiler.

Use a low water cutoff that breaks the 120 VAC supply to the boiler. Do not attempt to wire a 24-volt low water cutoff into the boiler factory wiring.

- h. Manual Reset High Limit (Required by some codes) - This control is required by ASME CSD-1 and some other codes. Install the high limit in the boiler supply piping just beyond the boiler with no intervening valves. Set the manual reset high limit as far above the operating limit setting as possible, but not over 240°F. Wire the control to break the 120 VAC electrical supply to the boiler.
- i. Flow Control Valve (Required under some conditions) - The flow control valve prevents flow through the system unless the circulator is operating. A flow control valve may be necessary on converted gravity systems to prevent gravity circulation. Flow control valves are also used to prevent “ghost flows” in circulator zone systems through zones that are not calling for heat.
- j. Isolation Valves (Optional) - Isolation valves are useful if the boiler must be drained, as they will eliminate having to drain and refill the entire system.

B. Piping for Special Situations

1) Certain types of heating systems have additional requirements. Some of the more common variations follow:

- a. Large Water Volume Systems - The bypass piping shown in Figure 18 will minimize the amount of time that the boiler operates with return temperatures below 120°F on these systems. A bypass is installed as shown to divert some supply water directly into the return water. The bypass pipe should be the same size as the supply. The two throttling valves shown are adjusted so that the return temperature rises above 120°F during the first few minutes of operation. A three-way valve can be substituted for the two throttling valves shown. If the circulator is mounted on the supply, the bypass must be on the discharge side of the circulator.
- b. Systems containing oxygen - Many hydronic systems contain enough dissolved oxygen to cause severe corrosion damage to a cast iron boiler such as the Series 16. Some examples include:
 - Radiant systems that employ tubing without an oxygen barrier.
 - Systems with routine additions of fresh water.
 - Systems which are open to the atmosphere.

If the boiler is to be used in such a system, it must be separated from the oxygenated water being heated with a heat exchanger.

Consult the heat exchanger manufacturer for proper heat exchanger sizing as well as flow and temperature requirements. All components on the oxygenated side of the heat exchanger, such as the pump and expansion tank, must be designed for use in oxygenated water.

- c. Piping with a Chiller - If the boiler is used in conjunction with a chiller, pipe the boiler and chiller in parallel as shown in Figure 19. Use isolation valves to prevent chilled water from entering the boiler.
- d. Air Handlers - Where the boiler is connected to air handlers through which refrigerated air passes, use flow control valves in the boiler piping or other automatic means to prevent gravity circulation during the cooling cycle.

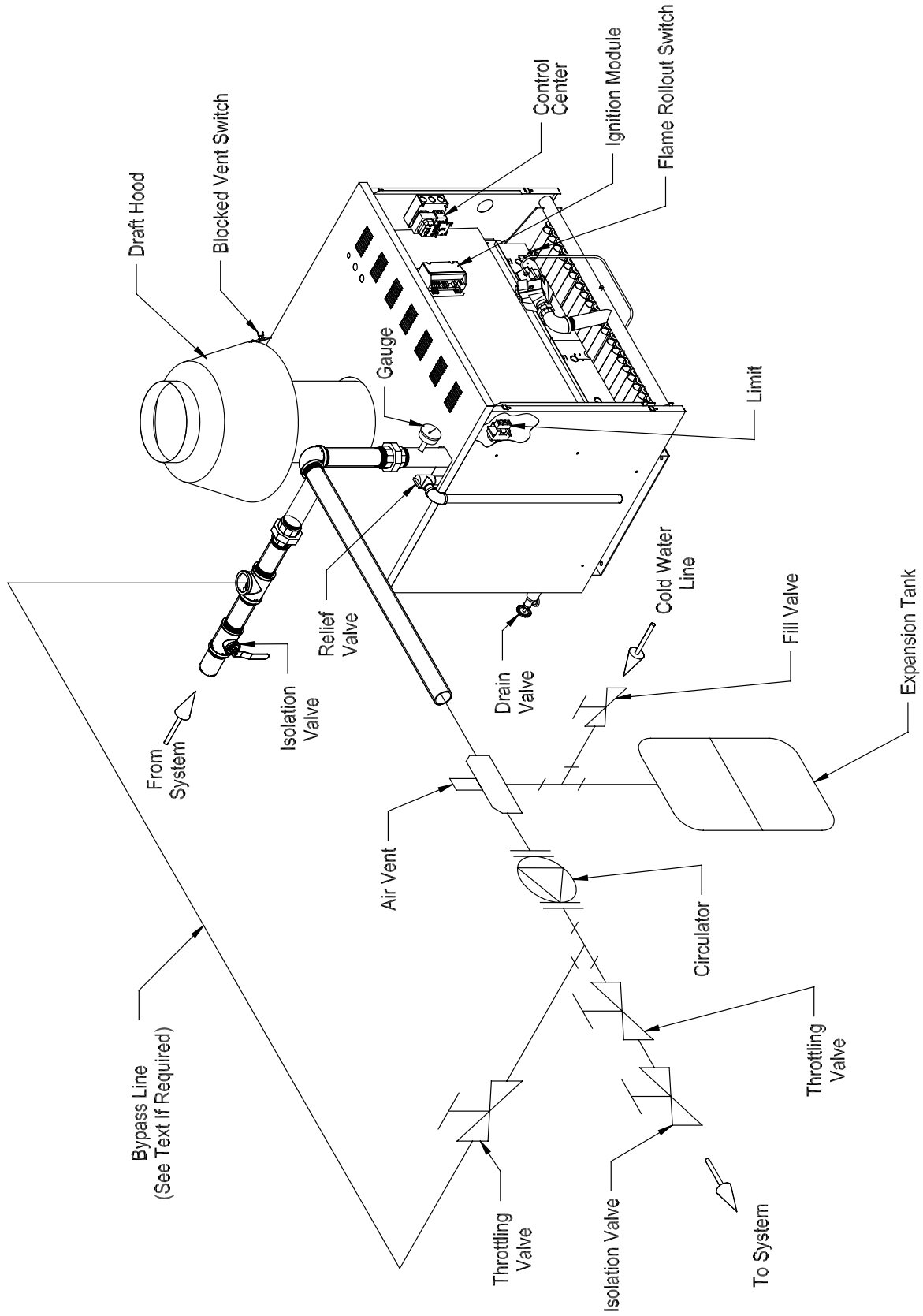

Figure 18: Standard Boiler Piping

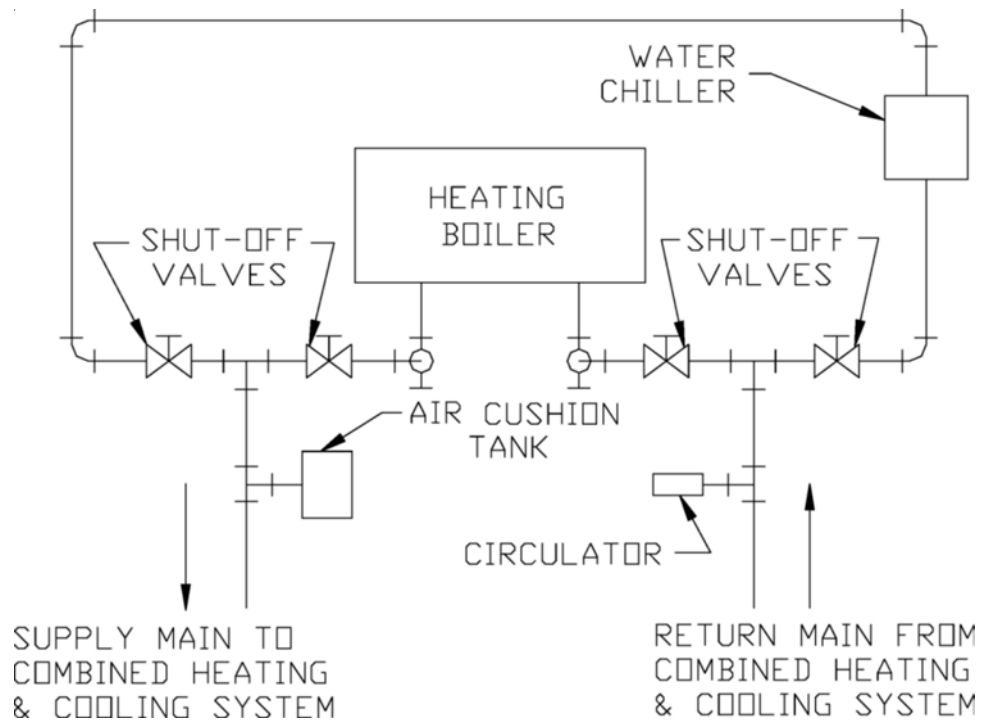

Figure 19: Recommended Piping for Combination Heating & Cooling (Refrigeration) System

IX Gas Piping

- 1) Gas piping to the boiler must be sized to deliver an adequate supply of gas for the boiler to fire at the nameplate input with the inlet pressure at the gas valves between the minimum and maximum values shown on the rating plate. For more information on gas line sizing, consult the Utility or the *National Fuel Gas Code*.
- 2) Figure 20 shows the typical gas piping connection(s) to the Series 16 boiler. A sediment trap must be installed upstream of all gas controls. Install a manual shut-off valve and ground joint union as shown.
- 3) Be sure to use a pipe thread compound (pipe dope) compatible with the fuel type to be used i.e. NG (natural gas) or LP (liquefied petroleum) for all gas line connections.
- 4) The use of teflon tape is not recommended for use on gas line connections.
- 5) The boiler and its gas connection must be leak tested before placing the boiler in operation. When doing this, the boiler and its individual shut-off must be disconnected from the rest of the system during any pressure testing of that system at pressures in excess of 1/2 psi. When pressure testing the gas system at pressures of 1/2 psi or less, isolate the boiler from the gas supply system by closing its individual manual shut-off valve.

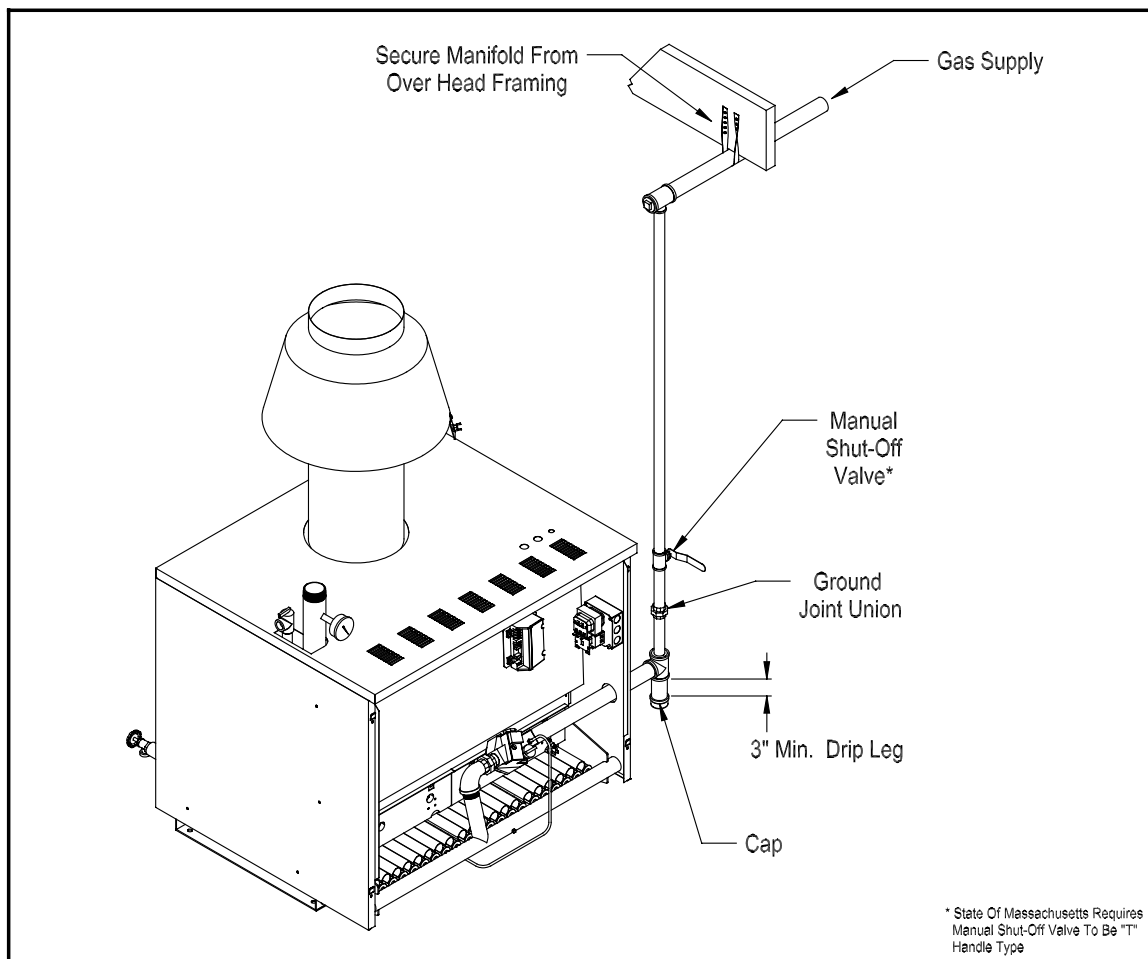

Figure 20: Gas Main Piping And Branch Connections To Boiler

X Control System Wiring

WARNING

All wiring and grounding must be done in accordance with the authority having jurisdiction or, in the absence of such requirements, with the National Electrical Code (ANSI/NFPA 70).

- 1) Provide the boiler with a dedicated branch circuit with a fused disconnect. The minimum rating of this circuit must be 15A.
- 2) Locate the supplied wire harnesses and wire the boiler following the appropriate wiring diagram in Figures 21 or 22. Use 14 gauge wire for all 120 volt wiring to circulators, low water cut-offs and auxiliary manual reset hi limits switches supplied by others. The junction box located on the inside right side jacket panel is to become the hub for all limit and low water cut-off wiring. All 120 volt boiler wiring must be enclosed in conduit.
- 3) Make sure that all single pole switches and safety controls supplied by others are in the “hot” (ungrounded) side of the circuit.
- 4) If a LWCO and or manual reset limit are used, wire them so that they break the 120 volt “Hot” connection to the boiler. Do not install these devices in the 24 volt factory wiring.
- 5) When wiring the optional vent damper attach the quick connect end of the supplied wire harness to the mounting bracket on the vent and plug the quick connect into the receptacle on the vent damper. Attach the BX cable connector located on the other end of the harness to one of the knockouts on the jacket top panel. Remove the factory installed jumper plug from the vent damper receptacle located in the vestibule and insert the plug from the vent damper harness into the vent damper receptacle. Cut the jumper wire on the jumper plug and discard it.

DANGER

Do not attempt to reuse the jumper plug on boilers installed with vent dampers. Flue gas spillage can occur resulting in severe injury or death.

- 6) The 24 volt “thermostat / operating control” shown in Figures 21 and 22 is not supplied. It is the control that turns the boiler on in response to a call for heat. Follow the thermostat / operating control instructions for placement and wiring. Provide Class II circuit between the thermostat / operating control and the boiler. Wire the thermostat or operating control across terminals ‘G’ and ‘R’ on the Honeywell 8285D Control Center as shown in Figures 21 and 22. Set the heat anticipator on the thermostat to match the setting listed on the ignition control.
- 7) Attach the line voltage or “hot” side of the circulator motor supplied by others to the yellow wire from terminal 3 on the R8222U relay located on the Honeywell R8285D Control Center. Attach the neutral side of the circulator to the common leads in the junction box and ground as required by the circulator manufacturer. See Figures 21 and 22 for details.

Sequence of Operation – Vent Damper (If Used)

- 1) The vent damper is continuously powered at terminal 1.
- 2) On a call for heat, the damper relay coil is energized through terminal 2 if all the limits ahead of the damper are satisfied.
- 3) The relay coil closes contacts which energize the damper motor, causing the damper to open.
- 4) When the damper blade reaches the fully open position, power is sent back to the ignition circuit through terminal 3 and the damper motor is de-energized.

- 5) When a call for heat is satisfied, the damper relay coil is de-energized - closing the contacts which energize the damper motor. This causes the damper to close. When the damper blade reaches the fully closed position, the damper motor is de-energized.
- 6) Should a power failure occur, the damper blade will stop in the position it was in when power was lost. Combustion can never take place unless the damper blade is in the fully open position.

Sequence of Operation – Standard Boiler Wiring

- 1) All low water cut-offs and auxiliary limit controls are wired in series so that the boiler will not operate if any of these controls are open. Under normal circumstances, only the operating control contacts will be open.
- 2) Upon a call for heat, the operating control will make and the vent damper (if used) will open. Simultaneously, 120 volts will be applied to the circulator.
- 3) 24 volts will then appear across the “24V” and “24V (GND)” terminals on the ignition modules.
- 4) Upon application of voltage across the “24V” and “24V (GND)” terminals, the ignition module will start an ignition spark at the pilot and apply 24 volts across the pilot valve.
- 5) Once the pilot is established, the pilot flame will act as a diode, converting the AC current at the electrode to a half wave DC current at the pilot’s ground strap. This DC current flows through the boiler to the “GND (BURNER)” connection on the ignition module.
- 6) Once the ignition module detects the presence of a pilot flame, voltage is applied across the main valve, opening the valve and establishing main flame.
- 7) The way in which the ignition module handles failure to establish pilot or the loss of an already established pilot depends upon the exact ignition module supplied with the boiler. For more information on module operation, consult the ignition module instructions supplied with the boiler or the local Crown representative.

Sequence of Operation – CSD-1 Boiler Wiring

- 1) All low water cut-offs, limit controls, and the operating contacts are wired in series so that the boiler will not operate if any of these controls are open. Under normal circumstances, only the operating control contacts will be open.
- 2) Upon a call for heat, the operating control will make and the vent damper (if used) will open. Simultaneously, 120 volts will be applied to the circulator.
- 3) 24 volts will then appear across the “24V” and “24V (GND)” terminals on the ignition modules and on the “24VAC” and “COM” terminals on the 1145-2 Daughter Board.
- 4) The ignition module will start an ignition spark at the pilot and apply 24 volts across the pilot valve.
- 5) Once a pilot is established, the pilot flame will act as a diode, converting AC current at the pilot electrode to a half wave DC current at the pilot’s ground strap. This DC current flows through the boiler to the “GND” terminal on the ignition module.
- 6) Once the ignition module detects the presence of a pilot flame, voltage is applied across the main valve, opening the valve and establishing main flame.
- 7) If the pilot flame is not established during the trial for ignition period, or if the pilot signal is lost after the main flame is established, the module will de-energize the open pilot valve and main valve (if open) and wait 5 minutes. It will then repeat steps 4-6. If the pilot is still not established, the Alarm contacts on the ignition module will make. This will cause the 1145-2 Daughter Board to break power to the ignition module and illuminate the red LED on the Daughter Board. The ignition module will remain de-energized until the reset button on the daughter board is pressed.

SERIES 16 - BASIC BOILER WIRING

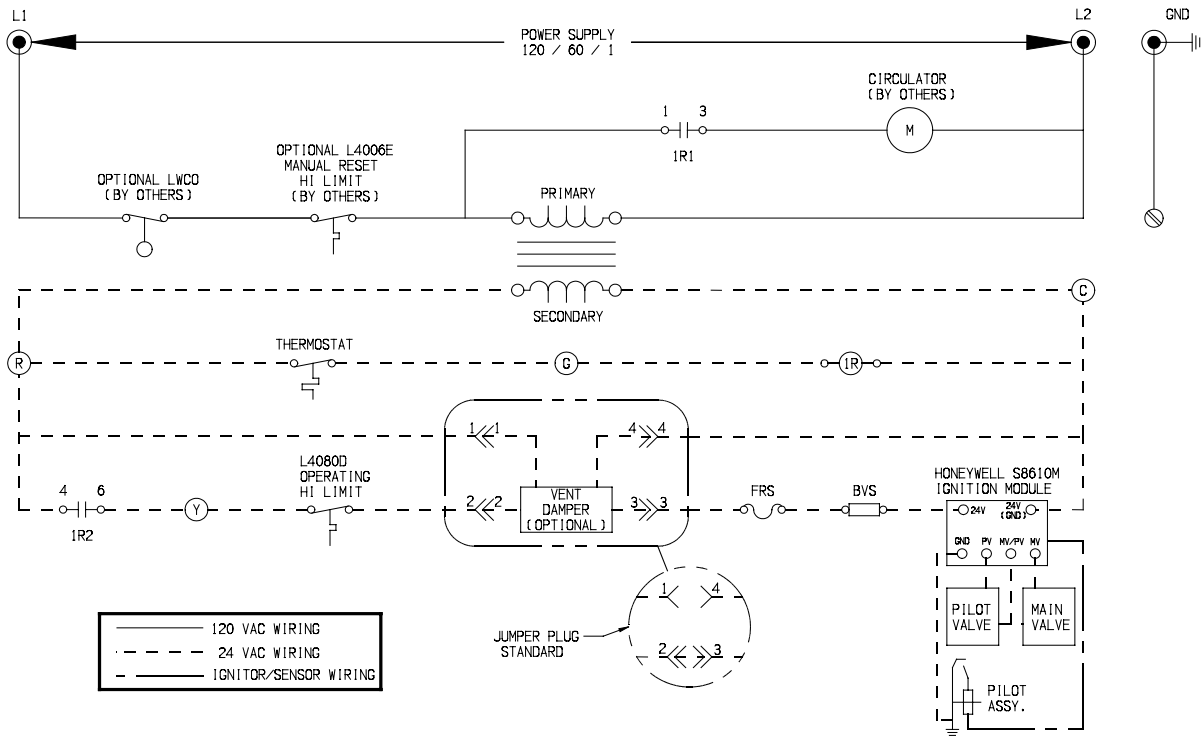
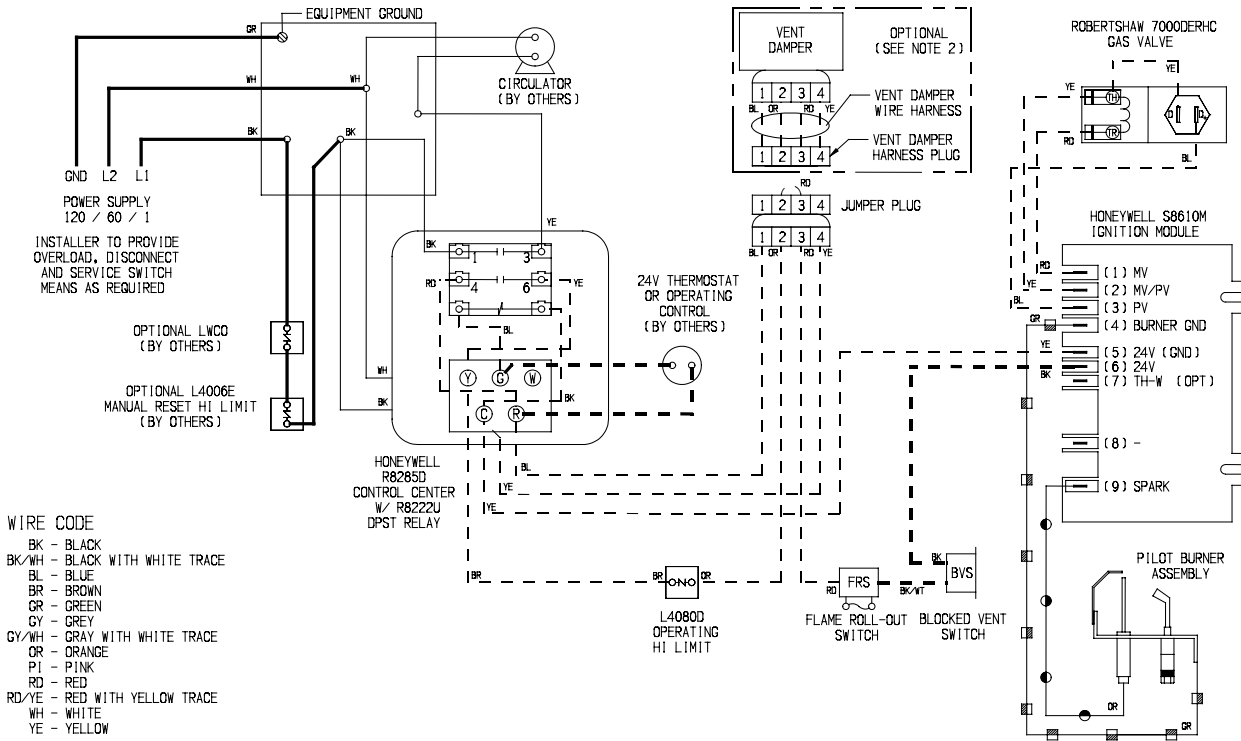
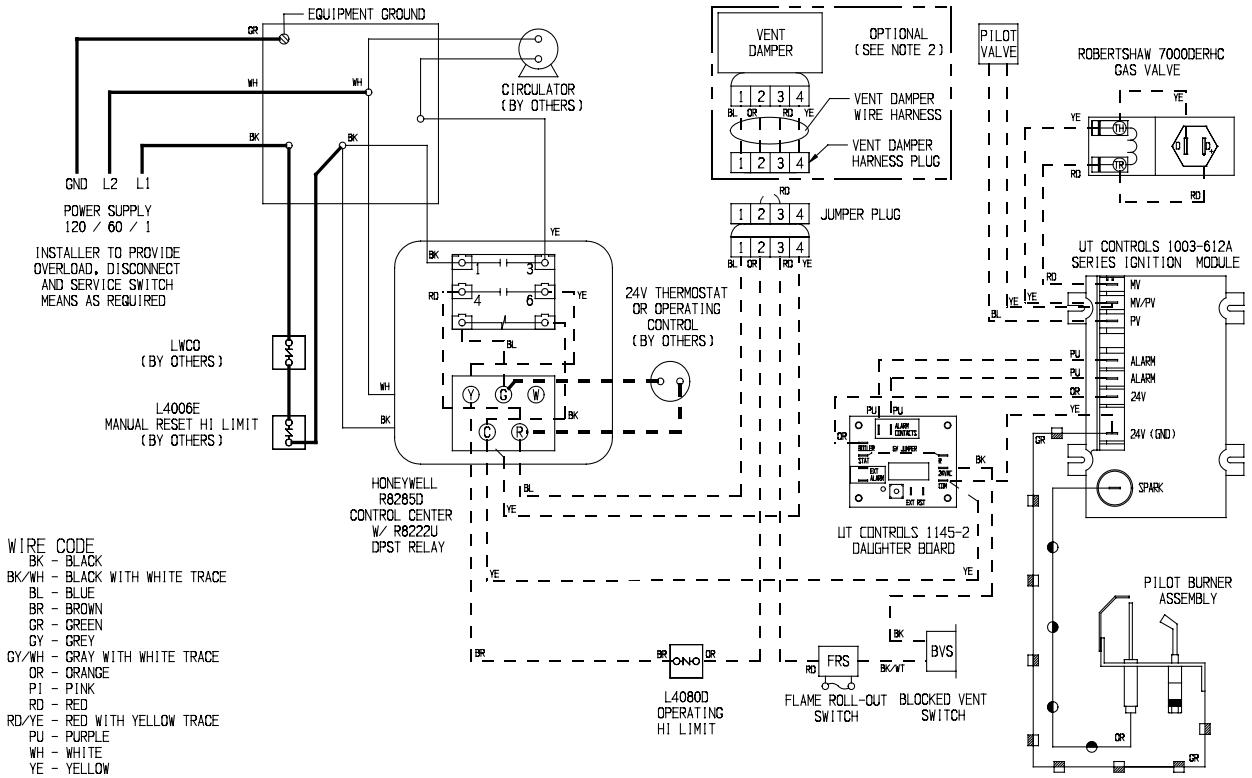

Figure 21: Series 16 Standard Boiler Wiring

SERIES 16 - CSD-1 BOILER WIRING



- WIRE CODE**
 BK - BLACK
 BK/WH - BLACK WITH WHITE TRACE
 BL - BLUE
 BR - BROWN
 GR - GREEN
 GY - GREY
 GY/WH - GRAY WITH WHITE TRACE
 OR - ORANGE
 PI - PINK
 RD - RED
 RD/YE - RED WITH YELLOW TRACE
 PU - PURPLE
 WH - WHITE
 YE - YELLOW

WIRE TYPE LEGEND

- - - - - LOW VOLTAGE SIZE 18 AWG TYPE TW/AWM STRANDED WIRE - 105°C
- - - - - LOW VOLTAGE SIZE 18/2 AWG TYPE CL2X CIRCUIT CABLE - 105°C
- LINE VOLTAGE SIZE 14 AWG TYPE TW OR TEW/AWM WIRE
- LINE VOLTAGE SIZE 18 AWG TYPE TW OR TEW/AWM WIRE
- IGNITOR/SENSOR - HONEYWELL 394803-2 CABLE - 250°C
- GROUND - SIZE 18 AWG TYPE SF-2, STRANDED WIRE, 1/32" INSULATION - 200°C

- NOTES:** 1. IF ANY OF THE ORIGINAL WIRE SUPPLIED WITH THE APPLIANCE MUST BE REPLACED, IT MUST BE REPLACED WITH THE SAME TYPE SHOWN OR ITS EQUIVALENT.
 2. VENT DAMPER IS OPTIONAL - FOR BOILERS WITH VENT DAMPER, REPLACE THE JUMPER PLUG WITH THE VENT DAMPER HARNESS PLUG.

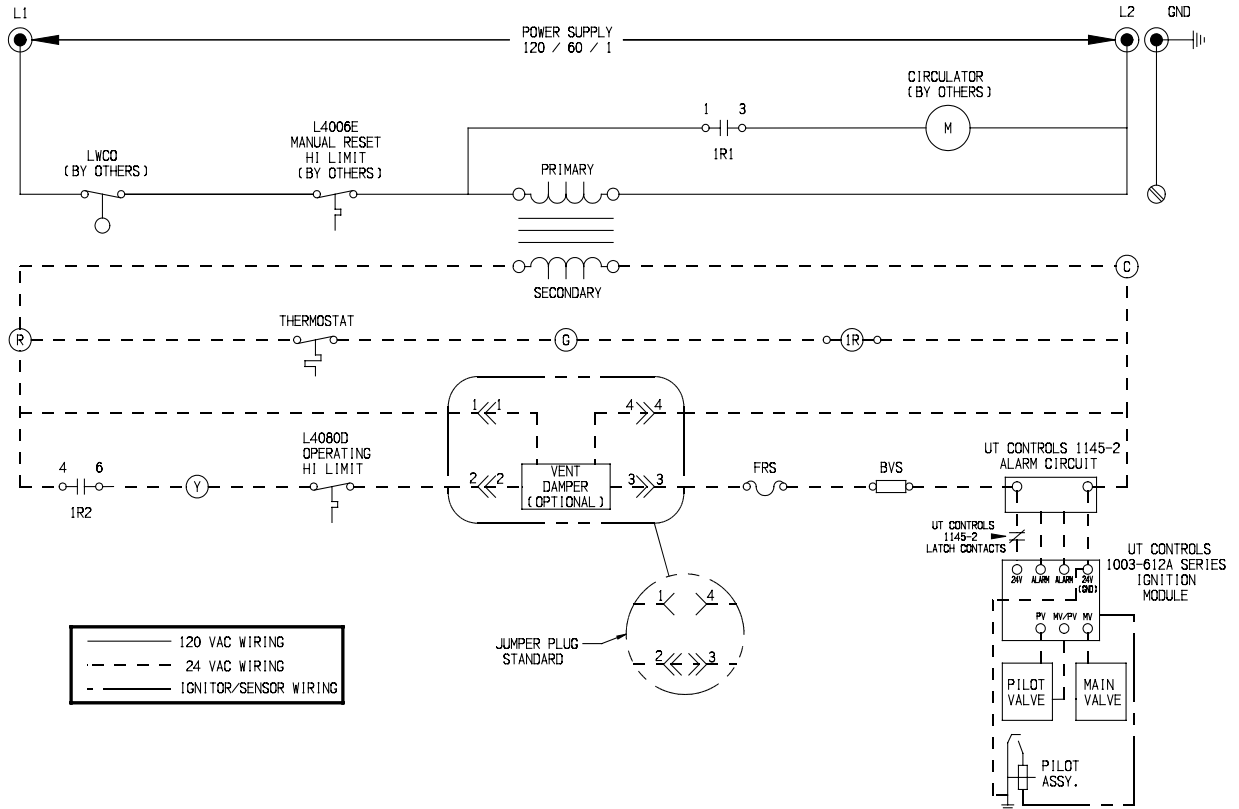

Figure 22: Series 16 - CSD-1 Boiler Wiring

Safety Control Operation

Temperature Limit Control – The temperature limit control interrupts burner operation when the supply water temperature exceeds the set point. Maximum allowable water temperature in a water boiler is 250F. The L4080D will reset itself when the water temperature drops below the set point less the differential (typically 15F). The circulator will continue to operate for as long as the thermostat or operating control calls for heat. If a vent damper is installed, it will close when the high limit opens. Manual reset water limit controls, such as the Honeywell L4006E, must be manually reset. For this reason, they should be set well above the operating limit control to avoid nuisance boiler shutdowns.

Blocked Vent Switch - The blocked vent switch automatically interrupts main burner operation when flue gas spillage, caused by a complete vent blockage, occurs. The circulator continues to operate and the vent damper (if used) remains open with a call for heat. If the blocked vent switch is activated, do not attempt to place the boiler in operation. Correct the cause of the spillage and reset the blocked vent switch.

Flame Roll-out Switch - The flame roll-out switch automatically interrupts main burner operation when flames or excessive heat are present in the vestibule. The circulator continues to operate and the vent damper (if used) remains open with a call for heat. This control is a single use device. If the flame roll-out switch is activated, do not attempt to place the boiler in operation. Correct the cause of the spillage and replace the flame roll-out switch.

Low Water Cut-off (by others) – Low water cut-offs interrupt burner operation if the water level in the boiler drops below a safe level. See the manufacturer's instructions for further details on the operation of this safety control.

NOTE

SAFE LIGHTING AND OTHER PERFORMANCE CRITERIA WERE MET WITH THE GAS MANIFOLD AND CONTROL ASSEMBLY PROVIDED ON THE BOILER WHEN THE BOILER UNDERWENT THE TESTS SPECIFIED IN Z21.13.

XI Start-up and Checkout

Use the following procedure for initial start-up of the boiler:

- 1) Make sure that the boiler is filled with water.

WARNING

- NEVER ATTEMPT TO FILL A HOT EMPTY BOILER

- 2) Check all new gas piping for leaks and purge piping sections that are filled with air. See the *National Fuel Gas Code* for additional information on testing and purging gas lines.
- 3) Verify that vent system is complete and free of obstructions before attempting to fire boiler.
- 4) Inspect all wiring for loose or uninsulated connections.
- 5) Make sure the main burners are seated properly in the rear of burner tray and on orifices.
- 6) Adjust thermostat to the highest setting. Make sure the vent damper (if used) has fully opened.
- 7) Start the boiler using the appropriate lighting instructions for the gas valve on the boiler on page 34.

NOTE

The combustion chamber insulation panels in this boiler contain a cornstarch based binder which may emit a strong odor as it is burned out of the insulation when the boiler is fired for the first time. An hour or more of continuous firing may be required to burn off all of this binder. Open any windows and outside doors in the boiler room to maximize ventilation while this binder is burned out.

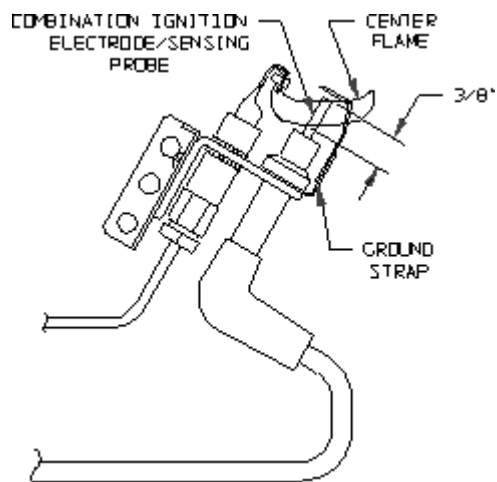

Figure 23: Pilot Burner Flame

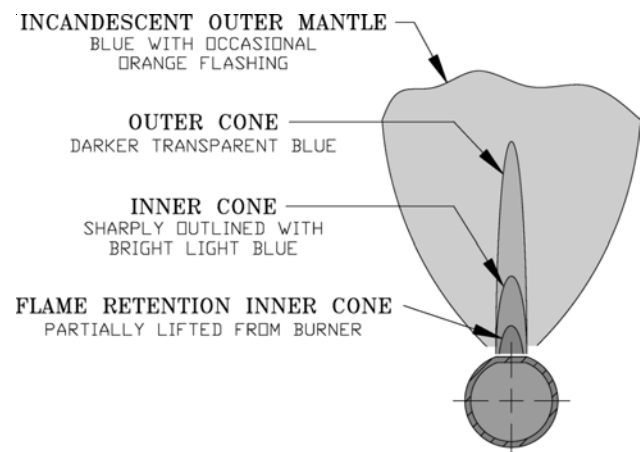

Figure 24: Main Burner Flame

- 8) Upon initial start-up, the gas train will be filled with air. Even if the gas line has been completely purged of air, it may take several tries for ignition before a flame is established. Once a flame has been established for the first time, subsequent calls for burner operation should result in a flame on the first try.
- 9) Observe pilot burner flame. See Figure 23. The pilot flame should be a steady medium blue flame covering around 3/8" to 1/2" of the spark electrode / flame rod.
- 10) Inspect the main burner flames visible through the observation port in burner access panel. The flame should be stable and mostly blue. See Figure 24. No yellow tipping should be present; however, intermittent flecks of yellow and orange in the flame are normal.
- 11) Check entire gas train for leaks using soap and water or other approved leak detection method while boiler is firing. Fix any leaks found immediately.

WARNING

- NEVER USE A FLAME TO CHECK FOR GAS LEAKS.
- MAKE SURE THAT THE AREA AROUND THE BOILER IS CLEAR AND FREE FROM COMBUSTIBLE MATERIALS, GASOLINE, AND OTHER FLAMMABLE VAPORS AND LIQUIDS.

- 12) Run the gas valve safety shutdown test with the main burners firing. Disconnect ignition cable from the ignition module on the boiler. Both the pilot burner and main burners should stop firing.
- 13) Check the manifold pressure and adjust if necessary. To do this, use the following procedure:

WARNING

FAILURE TO FOLLOW THE FOLLOWING PROCEDURE EXACTLY COULD RESULT IN OVER-FIRING OF THE BOILER AND A CARBON MONOXIDE HAZARD.

- a. Connect a manometer to the inlet pressure tap on the gas valve (See Figure 25).
- b. Check the inlet pressure with all gas appliances on and off. The inlet pressure at the inlet of each gas valve must be within the following limits regardless of what combination of appliances is firing:

Inlet Press (inches w.c.)	Natural Gas	LP Gas
Min.	5.0	11.0
Max.	14.0	14.0

If the inlet pressure falls outside of these limits, find and correct the cause of the problem before proceeding further.

- c. Connect a manometer to the manifold (outlet) pressure tap on the gas valve on the first base module. See Figure 25.
- d. Read the manifold pressure. It should be set at:

	Natural Gas	LP Gas
Manifold Pressure (inches w.c.)	3.5	10.0
- e. If a manifold pressure adjustment is needed, make the adjustment by turning the pressure regulator screw (See Figure 25) clockwise to raise the pressure and counter clockwise to reduce the pressure. If a manifold pressure adjustment is made, recheck the line pressure to be certain that it is still within acceptable limits.
- f. Replace the cover screw on the regulator.

- 14) Test thermostat operation while the boiler is running. Turn the thermostat to the lowest setting. Both pilot burner and main burners should stop firing and the vent damper (if used) should close. Raise the thermostat back to the highest setting. The vent damper (if used) should open and the pilot burner and main burners should relight.
- 15) Verify high limit operation. Allow the boiler water temperature to increase to high limit setting. The burners should shut down, the circulator continues running and the vent damper (if used) closes. Allow the boiler water temperature to drop below high limit setting. The vent damper (if used) should open and the pilot burner and main burners should relight.
- 16) Inspect the vent system for flue gas leaks. Repair any leaks found before leaving the boiler in operation.
- 17) After the boiler has operated for approximately 30 minutes, check the boiler and heating system piping for leaks. Repair any leaks found at once.
- 18) Review the "USER'S INFORMATION MANUAL" and system operation with the owner or operator.

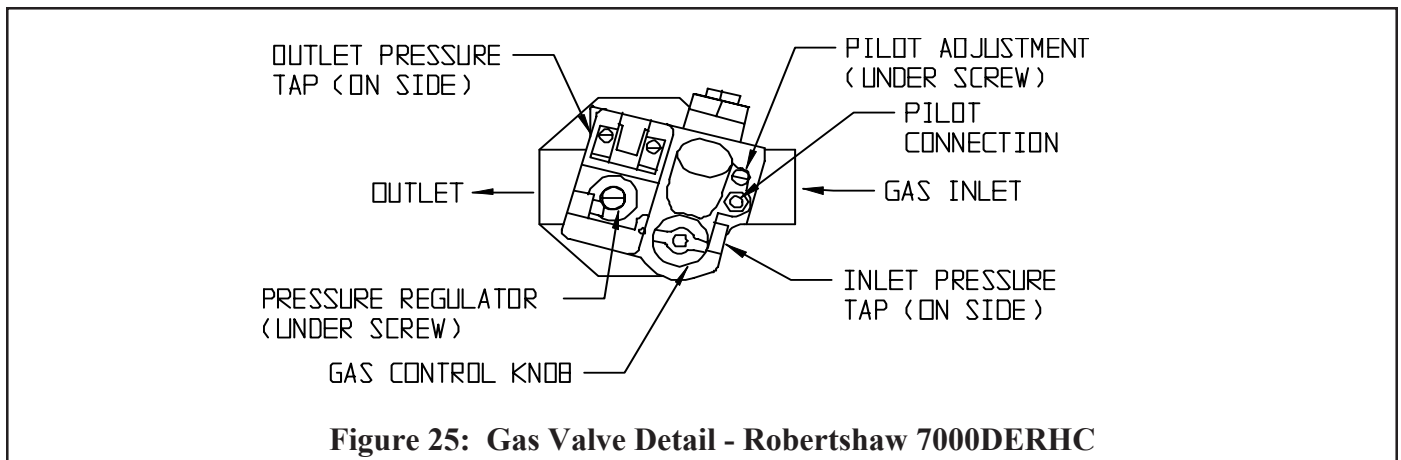

LIGHTING INSTRUCTIONS FOR BASE MODULES EQUIPPED WITH ROBERTSHAW 7000DERHC SERIES GAS VALVES

FOR YOUR SAFETY READ BEFORE LIGHTING

WARNING: If you do not follow these instructions exactly, a fire or explosion may result causing property damage, personal injury or loss of life.

A. This appliance is equipped with an ignition device which automatically lights the pilot. Do not try to light the pilot by hand.

B. **BEFORE LIGHTING** smell all around the appliance area for gas. Be sure to smell next to the floor because some gas is heavier than air and will settle on the floor.

WHAT TO DO IF YOU SMELL GAS

- Do not try to light any appliance.
- Do not touch any electric switch; do not use any phone in your building.
- Immediately call your gas supplier from a neighbor's phone. Follow the gas supplier's instructions.

- If you cannot reach your gas supplier, call the fire department.

C. Use only your hand to push in or turn the gas control knob. Never use tools. If the knob will not push in or turn by hand, don't try to repair it, call a qualified service technician. Force or attempted repair may result in a fire or explosion.

D. Do not use this appliance if any part has been under water. Immediately call a qualified service technician to inspect the appliance and to replace any part of the control system and any gas control which has been under water.

OPERATING INSTRUCTIONS

1. **STOP!** Read the safety information above on this label.
2. Set the thermostat to lowest setting.
3. Turn off all electric power to the appliance.
4. This appliance is equipped with an ignition device which automatically lights the pilot. Do not try to light the pilot by hand.

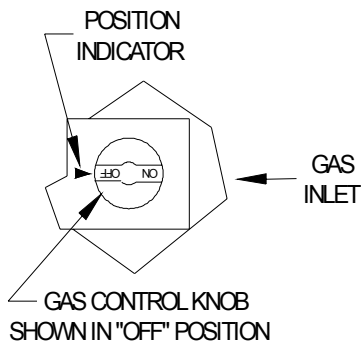

5. Remove front access panel.
6. Rotate the gas control knob clockwise ↻ to OFF.
7. Wait five (5) minutes to clear out any gas. Then smell for gas, including near the floor. If you then smell gas, **STOP!** Follow "B" in the safety information above on this label. If you don't smell gas go to the next step.
8. Rotate the gas control knob counter clockwise ↻ to "ON".
9. Replace front access panel.
10. Turn on all electric power to the appliance.
11. Set thermostat to desired setting.
12. If the appliance will not operate, follow the instructions "To Turn Off Gas To Appliance" and call your service technician or gas supplier.

TO TURN OFF GAS TO APPLIANCE

1. Set the thermostat to lowest setting.
2. Turn off all electric power to the appliance if service is to be performed.
3. Push in gas control knob slightly and turn clockwise ↻ to "OFF". Do not Force.

XII Service and Maintenance

The following routine maintenance should be performed:

On a continuous basis:

- 1) Keep the area around the boiler free and clear from combustible materials, gasoline, and other flammable vapors and liquids.
- 2) Keep the area around the boiler and boiler room ventilation openings clear of objects which might obstruct the flow of combustion and ventilation air.

On an annual basis:

- 1) Turn off electrical power and gas supply to the boiler.
- 2) Inspect the flue passages for signs of blockage. If there is any carbon in the combustion chamber or the flue passages, clean the heat exchanger before proceeding further. See the cleaning procedure on the next page.
- 3) Remove any debris found in the combustion chamber, being careful not to disturb combustion chamber insulation.
- 4) Remove all burners, noting the location of the pilot main burner. If burners show signs of deterioration, they should be replaced (some discoloration around the burner ports is normal). Clean the burners by first brushing the ports with a soft bristle brush and then vacuuming out any debris through the venturi opening.
- 5) Inspect the pilot assembly. Clean any deposits found on the electrode and grounding strap. The ideal gap between the electrode and the ground strap is 1/8". Inspect the porcelain for cracks or other deterioration. Replace pilot assembly if deterioration is found.
- 6) Inspect the combustion chamber insulation for deterioration.
- 7) Inspect the ignition cable insulation for cracks or other deterioration. If deterioration is found, replace cable.
- 8) Reinstall burners, being careful to put the pilot main burner in its original location.
- 9) Inspect all boiler wiring for loose connections or deterioration.

CAUTION

LABEL ALL WIRES PRIOR TO DISCONNECTION WHEN SERVICING CONTROLS. WIRING ERRORS CAN CAUSE IMPROPER AND DANGEROUS OPERATION. VERIFY PROPER OPERATION AFTER SERVICING.

- 10) Inspect the vent system:
 - Make sure that the vent system is free of obstructions.
 - Make sure that all vent system supports are intact.
 - Inspect joints for signs of condensate or flue gas leakage.
 - Inspect venting components for corrosion or other deterioration. Replace any defective vent components.
- 11) Inspect the boiler system for leaks.

CAUTION

WATER LEAKS CAN CAUSE SEVERE CORROSION DAMAGE TO THE BOILER OR OTHER SYSTEM COMPONENTS. REPAIR ANY LEAKS FOUND IMMEDIATELY.

- 12) Place the boiler back in operation using the procedure outlined in "Start-up". Check the pilot line and any other gas piping disturbed during the inspection process for leaks.

Heat Exchanger Cleaning Procedure

- 1) Turn off electrical power and gas supply to the boiler.
- 2) Disconnect the vent connector from the boiler.
- 3) Remove the blocked vent switch and the draft hood.
- 4) Remove the door panel and the top jacket panel.
- 5) Remove the burner access panels.
- 6) Remove the burners and inspect them for foreign debris and restrictions.
- 7) Clean the burners with a soft bristle brush and vacuum as necessary.
- 8) Remove the nuts and washers holding the flue collector onto the heat exchanger.
- 9) Remove the flue collector from the heat exchanger.
- 10) Clean the flue passageways using a stiff bristle brush. Be certain that all foreign material is removed from the gaps between the pins.
- 11) Clean the bottom surfaces of the heat exchanger.
- 12) Put a light in the combustion chamber and look through the flue passages from the top to verify that they have been thoroughly cleaned.
- 13) Replace the nuts and washers that hold down the flue collector.
- 14) Reseal the flue collector to the heat exchanger using furnace cement. The flue collector must be thoroughly sealed to the heat exchanger.
- 15) Reattach all the jacket components.
- 16) Reinstall burners, being careful to put the pilot main burner in its' original location.
- 17) Reinstall the draft hood. Reinstall the blocked vent switch on the skirt of the draft hood as shown in Figure 16.
- 18) Reconnect the vent system including the optional vent damper (if previously installed).

WARNING

SOOT DEPOSITS IN THE FLUE PASSAGES ARE A SIGN THAT THE BOILER MAY BE OPERATING AT HIGH CARBON MONOXIDE (CO) LEVELS. AFTER CLEANING THE BOILER OF SOOT DEPOSITS, CHECK THE CO LEVEL IN THE FLUE GAS TO INSURE THAT THE BOILER IS OPERATING PROPERLY.

If it is necessary to check CO, use a combustion analyzer, or other instrument which is designed to measure CO in flue gas. A CO "sniffer" designed for testing CO levels in ambient air cannot be used to check boiler combustion. Take a flue gas sample by inserting a sample probe through a small (approx. 1/4") hole drilled in the draft hood pipe below the skirt. Do not take a sample until the boiler has been firing for at least five minutes. Be sure to seal the sample hole after test.

A normal CO reading for a Series 16 boiler is less than 50ppm (0.005%). A reading of more than 100ppm (0.01%) is indicative of a combustion problem.

Some causes of excessive CO include:

- Incorrectly sized main burner orifice for the altitude at which boiler is installed
- Crooked or out-of-round orifice holes (never attempt to drill orifice for this boiler in the field)
- Partially plugged flue passages
- Improper manifold pressure
- Foreign material in burner venturis or burner ports
- Leak in seal between flue collector and heat exchanger
- Inadequate supply of combustion air
- Draft hood which has been cut or modified

XIII PARTS

The following parts may be obtained from any Crown distributor. To find the closest Crown distributor, consult the area Crown representative or the factory at:

Crown Boiler Co.
 Customer Service
 P.O. Box 14818
 Philadelphia PA. 19134
 (215) 535-8900
www.crownboiler.com

For boilers installed at elevations above 2000 ft, consult the local Crown representative or the factory for the correct main burner orifice.

SERIES 16 MASTER PARTS LIST												
DESCRIPTION	BASE / HEAT EXCHANGER / FLUE COLLECTOR ASSEMBLY					FASTENER & TRIM CARTON	CONTROL COMPONENTS CARTON (STANDARD ONLY)	CONTROL COMPONENTS CARTON (CSD-1 ONLY)	JACKET PANEL CARTON	DRAFT HOOD CARTON	OPTIONAL COMBUSTIBLE FLOOR BASE	OPTIONAL VENT DAMPER KIT
BOILER MODEL	16-325	16-390	16-455	16-520	16-585	QUANTITY			PART #			
16-325	1					1	1	1	260206	260136	500506	260035
16-390		1				1	1	1	260207	260137	500507	260036
16-455			1			1	1	1	260208	260138	500508	260036
16-520				1		1	1	1	260209	260139	500509	260037
16-585					1	1	1	1	260210	260139	500510	260037

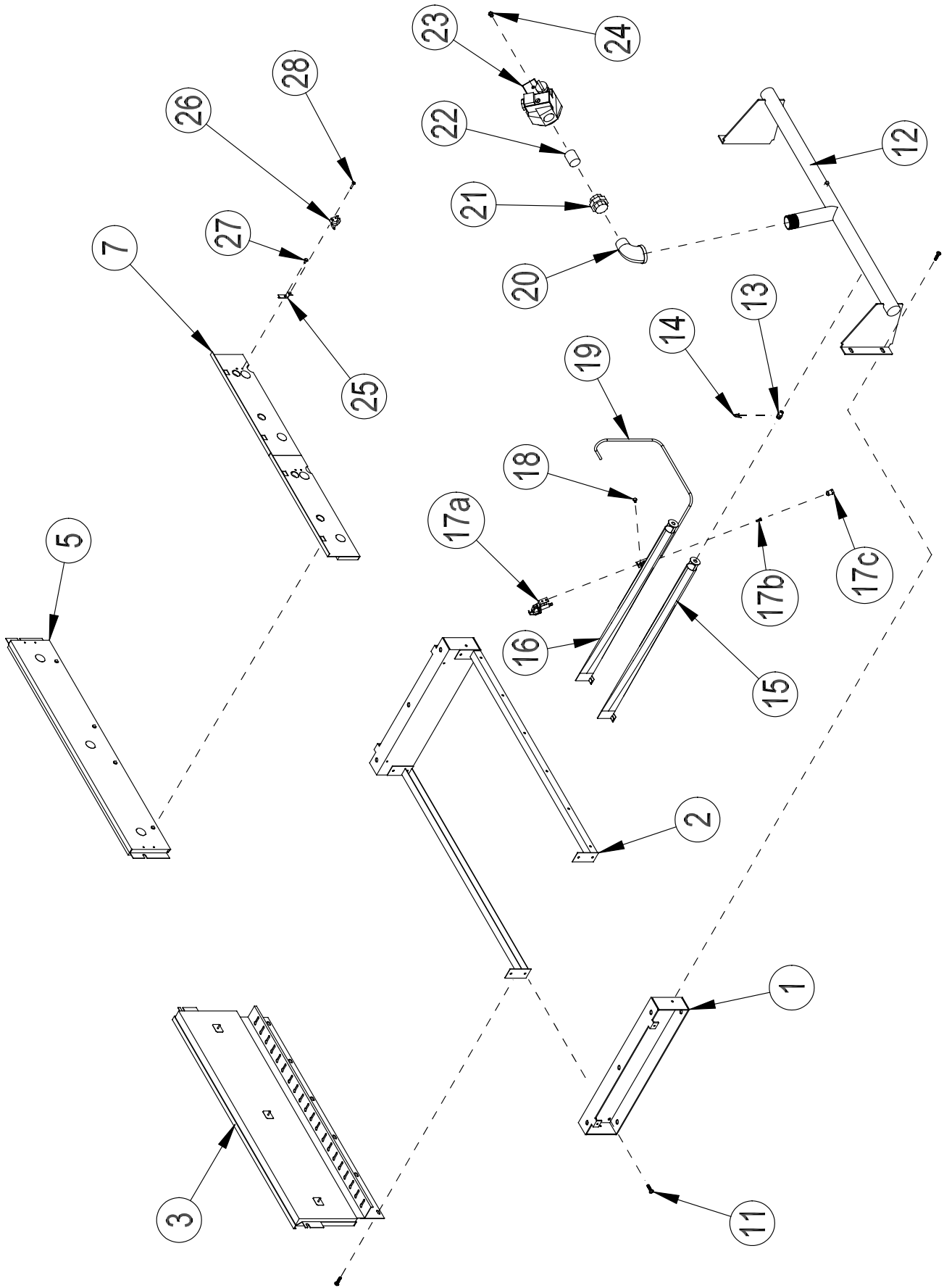

Figure 26: Exploded View - Base Parts & Manifold

BASE / MANIFOLD ASSEMBLY								
KEY	DESCRIPTION	CROWN PART #	QTY PER MODEL					
			16-325	16-390	16-455	16-520	16-585	
1	BASE END PANEL	260660	2	2	2	2	2	
2	BASE CHANNEL	16-325	260646	2				
		16-390	260647		2			
		16-455	260648			2		
		16-520	260649				2	
		16-585	260650					2
3	BASE REAR PANEL ASSEMBLY	16-325	260666	1				
		16-390	260667		1			
		16-455	260668			1		
		16-520	260669				1	
		16-585	260670					1
5	BASE FRONT PANEL ASSEMBLY	16-325	260606	1				
		16-390	260607		1			
		16-455	260608			1		
		16-520	260609				1	
		16-585	260610					1
7	BURNER ACCESS PANEL ASSEMBLY	16-325	260626	1				
		16-390	260627		1			
		16-455	260628			2		
		16-520	260629				2	
		16-585	260630					2
11	1/4-20 X 1/2 SELF TAPPING SCREW	900100	14	14	15	15	16	
12	GAS MANIFOLD	16-325	260156	1				
		16-390	260157		1			
		16-455	260158			1		
		16-520	260159				1	
		16-585	260160					1
13	MAIN BURNER ORIFICE - NAT GAS - DRILL # 38 (SEA LEVEL)	950362	11	13	16	18	20	
13	MAIN BURNER ORIFICE - LP - DRILL # 52 (SEA LEVEL)	950357	11	13	16	18	20	
14	ORIFICE HITCH PIN	950370	11	13	16	18	20	
15	MAIN BURNER LESS PILOT BRKT	150161	10	12	15	17	19	
16	MAIN BURNER WITH PILOT BRKT.	150160	1	1	1	1	1	
17a	PILOT ASSY, Q348A1275 (NAT GAS)	35-4700	1	1	1	1	1	
17a	PILOT ASSY, Q348A1259 (LP GAS)	35-4600	1	1	1	1	1	
17b	KF24 PILOT ORIFICE (NAT GAS) (INCLUDED IN PILOT ASSEMBLY)	-	1	1	1	1	1	
17b	KF16 PILOT ORIFICE (LP GAS) (INCLUDED IN PILOT ASSEMBLY)	-	1	1	1	1	1	
17c	1/4" COMPRESSION FERRULE	3501150	1	1	1	1	1	
18	10-32 X 3/16 MACHINE SCREW	146-95-301	2	2	2	2	2	
19	1/4" O.D. PILOT TUBING (ft)	900040	3	3	3	3	3	
20	1" 90° STREET ELBOW	950191	1	1				
20	1-1/4" X 1" 90° REDUCING STREET ELBOW	950193			1	1	1	
21	1" UNION	950101	1	1	1	1	1	
22	1" X 2" NIPPLE	950102	1	1	1	1	1	
23	GAS VALVE (NAT GAS), ROBERTSHAW 7000DERHC	3507310	1	1	1	1	1	
23	GAS VALVE (LP GAS), ROBERTSHAW 7000DERHC-LP	3507315	1	1	1	1	1	
24	1/4" FERRULE (INCLUDED WITH GAS VALVE)	3501155	1	1	1	1	1	
25	FLAME ROLL-OUT SWITCH MOUNTING BRACKET	900122	1	1	1	1	1	
26	FLAME ROLL-OUT SWITCH G4AM0600240C	960122	1	1	1	1	1	
27	#10 X 1/2 HEX HD SHEET METAL SCREW	90-212	1	1	1	1	1	
28	#8 X 3/4 SELF TAPPING SCREW	90-048	1	1	1	1	1	

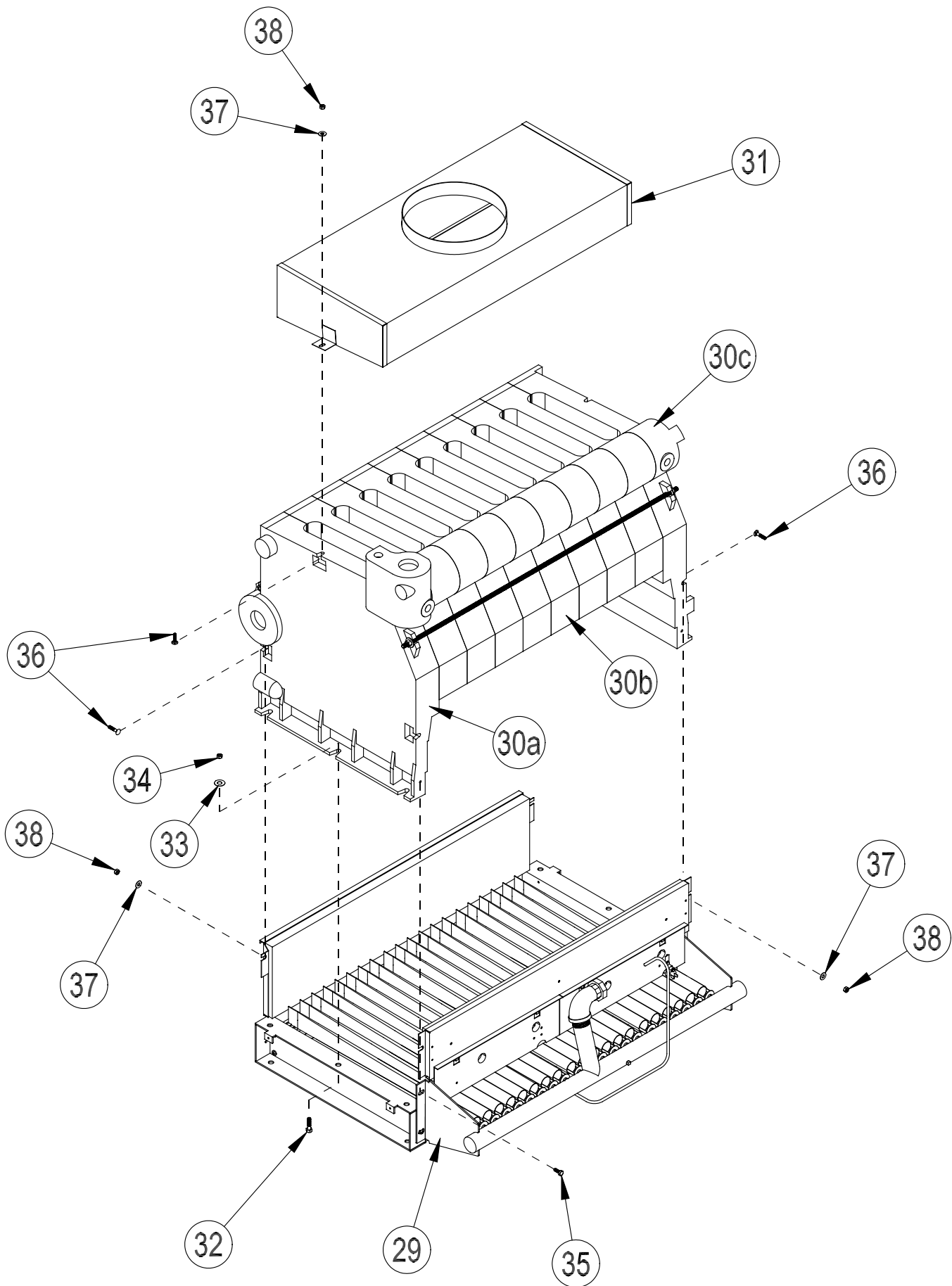

Figure 27: Exploded View - Base / Heat Exchanger / Flue Collector - Assembly

BASE / HEAT EXCHANGER / FLUE COLLECTOR - ASSEMBLY								
KEY	DESCRIPTION	CROWN PART #	QTY PER MODEL					
			16-325	16-390	16-455	16-520	16-585	
29	BASE ASSEMBLY	16-325	See Figure 26	1				
		16-390	See Figure 26		1			
		16-455	See Figure 26			1		
		16-520	See Figure 26				1	
		16-585	See Figure 26					1
30	HEAT EXCHANGER ASSEMBLY	16-325	260016	1				
		16-390	260017		1			
		16-455	260018			1		
		16-520	260019				1	
		16-585	260020					1
30a	LEFT END SECTION	260001	1	1	1	1	1	
30b	INTERMEDIATE SECTION	260002	4	5	6	7	8	
30c	RIGHT END SECTION	260000	1	1	1	1	1	
31	FLUE COLLECTOR	16-325	260126	1				
		16-390	260127		1			
		16-455	260128			1		
		16-520	260129				1	
		16-585	260130					1
32	5/16"-18 X 1-1/2" HEX HEAD CAP SCREW	900415	6	6	6	6	6	
33	3/8" FLAT WASHER	90-036	6	6	6	6	6	
34	5/16"-18 HEX NUT	90-910	6	6	6	6	6	
35	5/16"-18 X 3/4" HEX HEAD CAP SCREW	900400	2	2	2	2	2	
36	1/4"-20 X 1-1/4" CARRIAGE BOLT	90-201	6	6	6	6	6	
37	1/4" FLAT WASHER	90-215	6	6	6	6	6	
38	1/4"-20 HEX NUT	90-202	6	6	6	6	6	
*	3" PUSH NIPPLES (INCLUDED IN HEAT EXCHANGER ASSY)	260003	10	12	14	16	18	
*	FURNACE CEMENT (PINT CONTAINER)	900370	1	1	1	1	1	

* NOT PICTURED

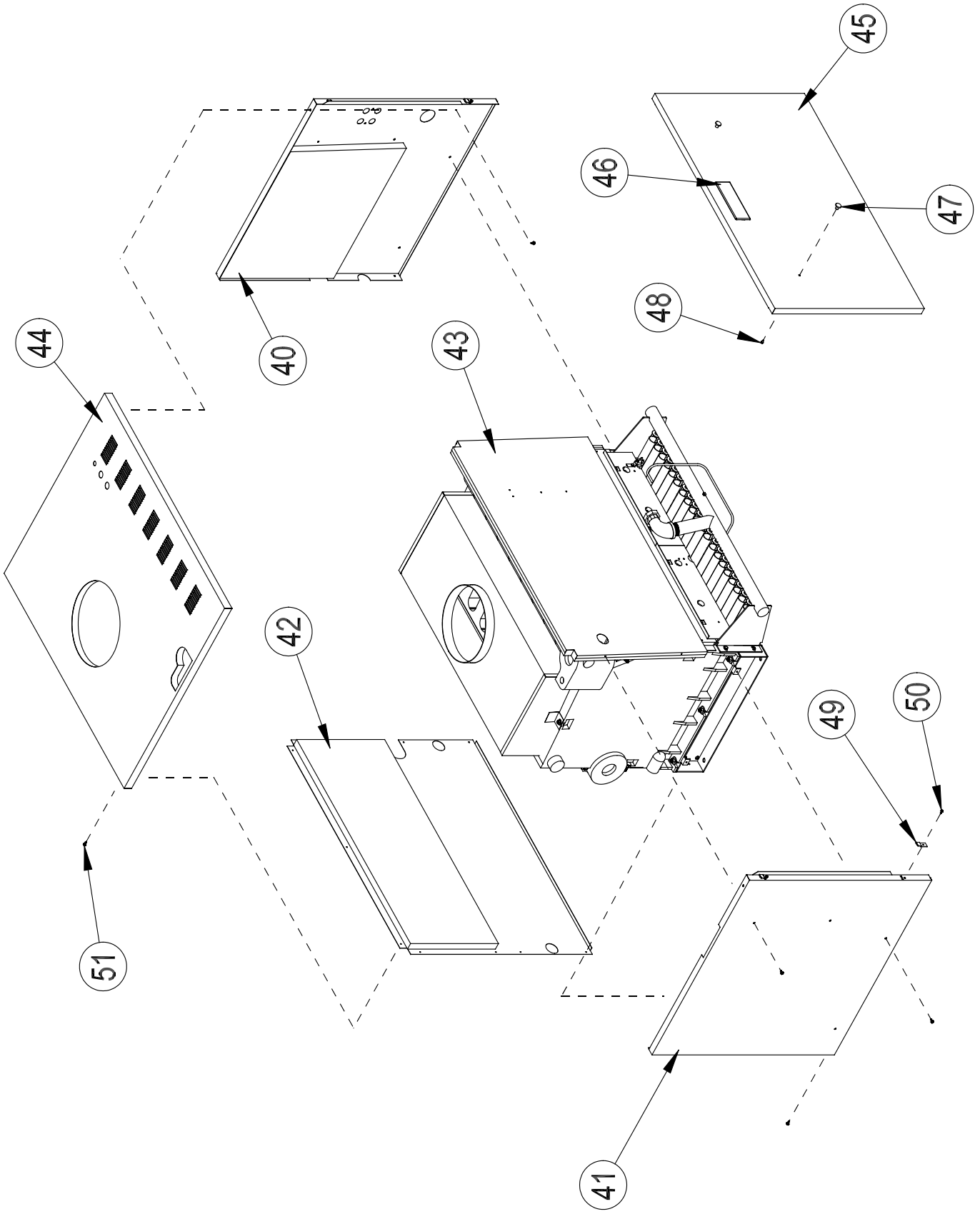

Figure 28: Exploded View - Jacket

JACKET PANEL CARTON								
KEY	DESCRIPTION	CROWN PART #	QTY PER MODEL					
			16-325	16-390	16-455	16-520	16-585	
40	RIGHT SIDE JACKET PANEL	260300	1	1	1	1	1	
41	LEFT SIDE JACKET PANEL	260301	1	1	1	1	1	
42	REAR JACKET PANEL	16-325	260306	1				
		16-390	260307		1			
		16-455	260308			1		
		16-520	260309				1	
		16-585	260310					1
43	VESTIBULE PANEL	16-325	260386	1				
		16-390	260387		1			
		16-455	260388			1		
		16-520	260389				1	
		16-585	260390					1
44	TOP JACKET PANEL	16-325	260326	1				
		16-390	260327		1			
		16-455	260328			1		
		16-520	260329				1	
		16-585	260330					1
45	JACKET DOOR PANEL	16-325	260316	1				
		16-390	260317		1			
		16-455	260318			1		
		16-520	260319				1	
		16-585	260320					1
46	CROWN LABEL (EMBOSSSED)	98-004	1	1	1	1	1	

* NOT PICTURED

FASTENER & TRIM CARTON								
KEY	DESCRIPTION	CROWN PART #	QTY PER MODEL					
			16-325	16-390	16-455	16-520	16-585	
47	DOOR KNOB	90-210	2	2	2	2	2	
48	#8-32 X 1/4" H.W.H. SCREW	90-211	2	2	2	2	2	
49	VERTICAL JACKET CLIP	800341	4	4	4	4	4	
50	#8-32 X 1/2" SELF TAPPING SCREW	90-223	4	4	4	4	4	
51	#10 X 1/2 HEX HD SHEET METAL SCREW	90-212	27	27	27	27	27	
52	#8-32 X 1/2" MACHINE SCREW	90-052	2	2	2	2	2	
53	#8-32 HEX NUT	90-053	2	2	2	2	2	
54	3/4" DRAIN VALVE	95-041	1	1	1	1	1	
55	3/4" NPT X 4-1/2" PIPE NIPPLE	95-102	2	2	2	2	2	
56	3/4" NPT COUPLING	95-056	1	1	1	1	1	
57	2" NPT X 10" PIPE NIPPLE WITH GAUGE TAPPING	950210	1	1	1	1	1	
58	3/4" NPT SAFETY RELIEF VALVE 30 PSI	95-040	1	1	1	1	1	
59	TEMPERATURE - PRESSURE GAUGE	95-069	1	1	1	1	1	
60	4 x 4 JUNCTION BOX	96-055	1	1	1	1	1	

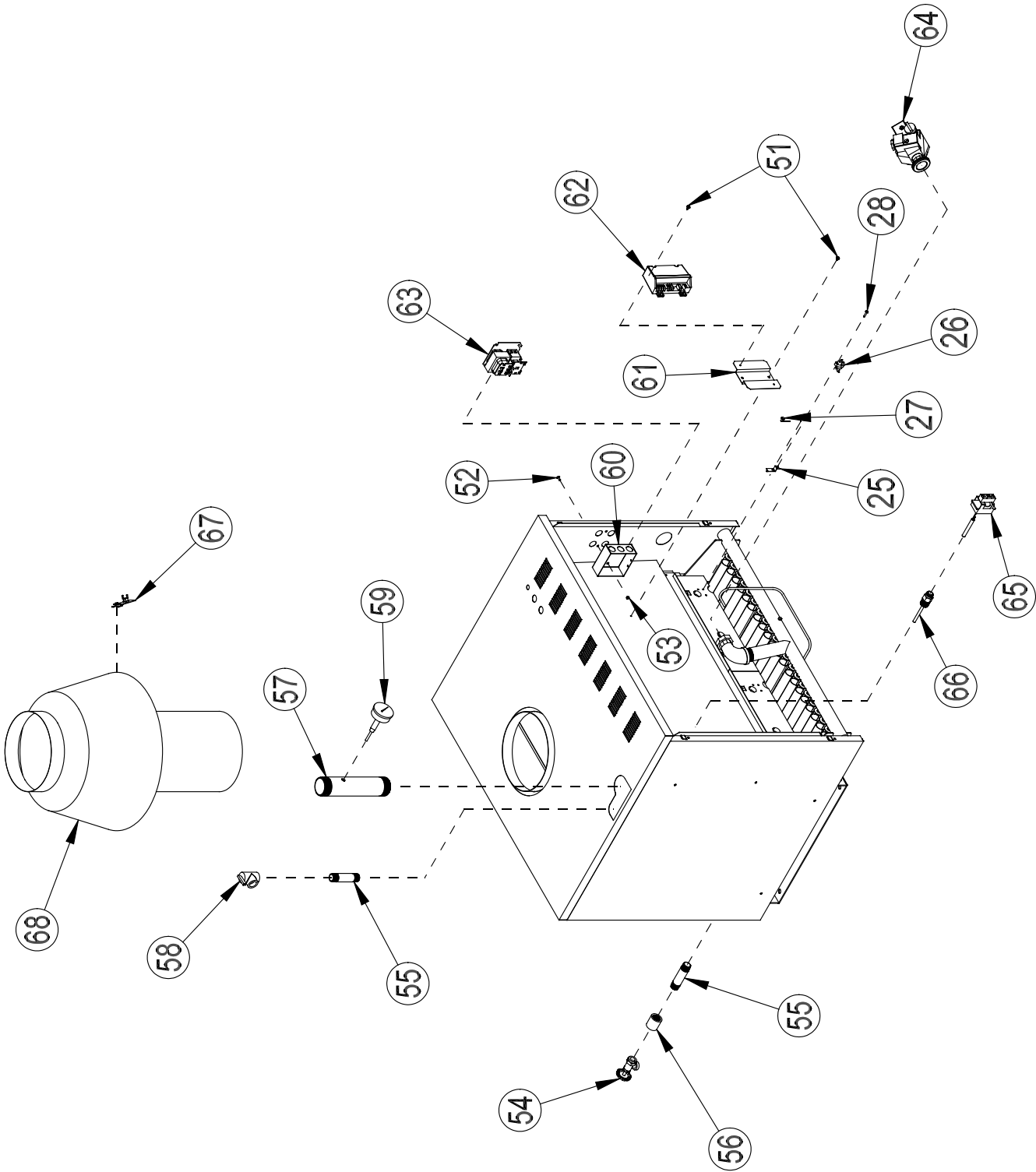

Figure 29: Exploded View - Trim & Control Components

CONTROL COMPONENTS CARTON							
KEY	DESCRIPTION	CROWN PART #	QTY PER MODEL				
			16-325	16-390	16-455	16-520	16-585
61	IGNITION MODULE MOUNTING BRACKET	905000	1	1	1	1	1
62	IGNITION MODULE, S8610M 1011 (STD ONLY)	3505015	1	1	1	1	1
63	CONTROL CENTER R8285D5001 WITH R8222U DPST RELAY	3505555	1	1	1	1	1
64	GAS VALVE TRAIN ASSEMBLY (NAT GAS) (STD ONLY)	-	1	1	1	1	1
64	GAS VALVE TRAIN ASSEMBLY (LP GAS) (STD ONLY)	-	1	1	1	1	1
65	OPERATING LIMIT L4080D1218	35-3300	1	1	1	1	1
66	3/4" NPT X 3" IMMERSION WELL	35-1010	1	1	1	1	1
67	BLOCKED VENT SWITCH	960123	1	1	1	1	1
*	STRAIN RELIEF BUSHING FOR BLOCKED VENT SWITCH WIRING	960010	1	1	1	1	1
*	IGNITION MODULE HARNESS (STD ONLY)	9605100	1	1	1	1	1
*	WIRE HARNESS ASSEMBLY (STD ONLY)	9605120	1	1	1	1	1
*	GROUND WIRE	9601101	1	1	1	1	1
*	36" IGNITION CABLE	3501136	1	1	1	1	1
*	GAS VALVE TRAIN ASSEMBLY (NAT GAS) (CSD-1 ONLY)	-	-	-	1	1	1
*	GAS VALVE TRAIN ASSEMBLY (LP GAS) (CSD-1 ONLY)	-	-	-	1	1	1
*	IGNITION MODULE, UT 1003-612A (CSD-1 ONLY)	3503100	-	-	1	1	1
*	DAUGHTER BOARD, UT 1145-2 (CSD-1 ONLY)	3503105	-	-	1	1	1
*	DAUGHTER BOARD MOUNTING BRACKET (CSD-1 ONLY)	310200	-	-	1	1	1
*	DAUGHTER BOARD COVER (CSD-1 ONLY)	310205	-	-	1	1	1
*	PILOT VALVE (CSD-1 ONLY)	3503107	-	-	1	1	1
*	RV12L PILOT REGULATOR - NAT/LP (CSD-1 ONLY)	3503115	-	-	1	1	1
*	"PILOT COMPRESSION" x 1/8" MNPT ADAPTER (CSD-1 ONLY)	900460	-	-	1	1	1
*	WIRE HARNESS ASSEMBLY (CSD-1 ONLY)	9605920	-	-	1	1	1
*	GAS VALVE HARNESS (CSD-1 ONLY)	9605900	-	-	1	1	1
*	ALARM HARNESS (CSD-1 ONLY - PURPLE)	9605902	-	-	2	2	2
*	"R-STAT" JUMPER HARNESS (CSD-1 ONLY - GRAY)	9605907	-	-	1	1	1
*	"IGNITION MODULE HARNESS" (CSD-1 ONLY- ORANGE)	9605905	-	-	1	1	1
*	CSD-1 WIRING LABEL (CSD-1 ONLY)	980965	-	-	1	1	1
*	INSTALLATION MANUAL	980416	1	1	1	1	1
*	USER'S MANUAL	980446	1	1	1	1	1

* NOT PICTURED

NOTE: SOME STANDARD FITTINGS USED ON CSD-1 MODEL BOILERS NOT LISTED - PROCURE THESE LOCALLY

OPTIONAL AUTOMATIC VENT DAMPER KIT								
KEY	DESCRIPTION	CROWN PART #	QTY PER MODEL					
			16-325	16-390	16-455	16-520	16-585	
*	OPTIONAL VENT DAMPER HARNESS	9605125	1	1	1	1	1	
*	OPTIONAL AUTOMATIC VENT DAMPER	16-325	96-035	1				
		16-390	96-036		1			
		16-455	96-036			1		
		16-520	96-037				1	
		16-585	96-037					1

* NOT PICTURED

CROWN Boiler Co.

Manufacturer of Hydronic Heating Products

P.O. Box 14818 3633 I. Street

Philadelphia, PA 19134

Tel: (215) 535-8900 • Fax: (215) 535-9736 • www.crownboiler.com